

BUTTERFLY VALVE SERIES

蝶阀系列

特点Feature

- 1、蝶板密封圈为软硬层叠式金属片，具有金属硬密封和弹性密封的双重优点，无论在低温和高温情况下，均具有优良的密封性能。
- 2、采用三维偏心结构，阀座与蝶板几乎无摩擦，具有越关越紧的密封功能。
- 3、阀体密封面，采用堆焊不锈钢、钴基硬质合金，密封面耐磨损，使用寿命长。
- 4、结构独特，操作灵活、省力、方便。不受介质压力的高、低影响，密封性能可靠，使用寿命长。通常的双偏心蝶阀像b(偏离管道中心)和a(偏离密封面中心线)所示的那样，目的是减少阀座与密封件之间大约15°行程的摩擦。

HPV增加了一个独特的偏心角 β ，倾斜的锥形不仅克服了阀门启闭中密封件和阀座之间所有接触摩擦，从而增加使用寿命，而且通过外力矩的改变可以任意调整其密封比压，使密封更为可靠，绝不会出现过关现象。

- 1、butterfly plate seal for the hard and soft layering pieces of metal with a metal seal and flexible seal the dual advantage of both low and high temperature cases, both with excellent sealing performance.
- 2、using three-dimensional eccentric structure, valve seat and butterfly plate almost no friction, with the more closed more tight sealing function.
- 3、valve sealing surface, using welding stainless steel, cobalt-based alloy, sealing surface wear resistance and long service life.
- 4、The structure is unique, the operation nimble, reduces effort, conveniently, the medium pressure high, the low influence, the sealing property not to be unreliable, the service life is long. The usual double eccentric butterfly valve, as b (deviate from the pipe center) and a (deviate from the sealing surface of the centerline) as shown in the aim of reducing valve seat and seal between the friction of approximately 15° travel.

HPV adds a unique eccentric angle β , slope of the cone not only overcome the valve open and close the seal and the seat all contacts between the friction, thereby increasing the service life, but also through changes in torque can be applied arbitrarily to adjust their seal over pressure, so that more reliable seal and never pass phenomenon occurs.

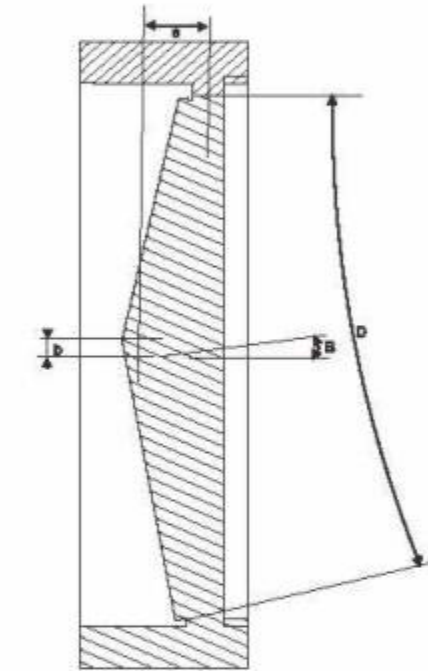

用途Uses

本蝶阀系吸收、消化国外技术，采用三维偏心多层次金属密封结构，适用介质温度 $\leq 550^{\circ}\text{C}$ 冶金、电力、石油化工以及给排水等管道上作调节流量和截断流体的最佳装置。

The valve system to absorb, digest foreign technology, using three-dimensional eccentric multi-level metal seal structure, applicable to medium temperature $\leq 550^{\circ}\text{C}$ metallurgy, electric power, petrochemical, as well as to the drainage pipe for regulating fluid flow and cut off the best device.

国标蝶阀 GB butterfly valve

标准与规范Standards and norms

设计与制造 Design and Manufacture	结构长度 Structure Length	压力-温度等级 Pressure - temperature rating	连接法兰 Connection flange	试验与检验 Test and Inspection
GB/12238 JB/T8527	GB/T 12221	GB/T 12224	HG /T20592	GB/T26480

主要性能规范Main performance standard

公称通径Nominal size	DN(mm)	50~2000				50~500
公称压力 Nominal Pressure	PN(MPa)	0.6	1.0	1.6	2.5	4.0
试验压力 Test Pressure	强度试验Strength test	0.9	1.5	2.4	3.75	6.0
	密封试验Seal test	0.66	1.1	1.76	2.75	4.4
	气密封试验Gas seal test	0.6	0.6	0.6	0.6	0.6
渗漏率Leakage	$0.1 \times \text{DNmm}^3/\text{s}$(符合GB/T13927-92标准) $0.1 \times \text{DNmm}^3/\text{s}$(in line with GB/T13927-92 standard)					
适用温度 Suitable temperature	碳钢: $-29^{\circ}\text{C} \sim 425^{\circ}\text{C}$; 不锈钢、铬钼钢: $-40^{\circ}\text{C} \sim 550^{\circ}\text{C}$ Carbon steel: $-29^{\circ}\text{C} \sim 425^{\circ}\text{C}$, stainless steel, chrome molybdenum steel: $-40^{\circ}\text{C} \sim 550^{\circ}\text{C}$					
适用介质 Applicable medium	空气、水、蒸气、煤气、油品以及酸、碱、盐带有弱腐蚀性介质等 Air, water, steam, gas, oil and acid, alkali, salt with a weak corrosive media, etc.					
驱动形式 Drive Type	蜗杆蜗轮传动、电传动 Worm worm transmission, electric transmission					

主要零件材质Main part materials

零件名称Part name	材料 Material	零件名称Part name	材料 Material
阀体Body	碳钢、不锈钢、铬钼钢、合金钢 Carbon steel, stainless steel, chrome molybdenum steel, alloy steel	阀杆Stem	2Cr13, 1Cr13不锈钢、铬钼钢 2Cr13, 1Cr13 stainless steel, chrome molybdenum steel
蝶板Disc	碳钢、合金钢、不锈钢、铬钼钢 Carbon steel, alloy steel, stainless steel, chrome molybdenum steel	轴承 Bearing	奥氏体不锈钢、304氮化 Austenitic stainless steel, 304 nitride
密封圈Ring	不锈钢与耐高温石棉板组合成多层次 Stainless steel and high temperature asbestos combined into multi-level	填料 packing	柔性石墨 Flexible graphite

国标对夹蝶阀

GB clamp butterfly valve

国标对夹蝶阀

GB clamp butterfly valve

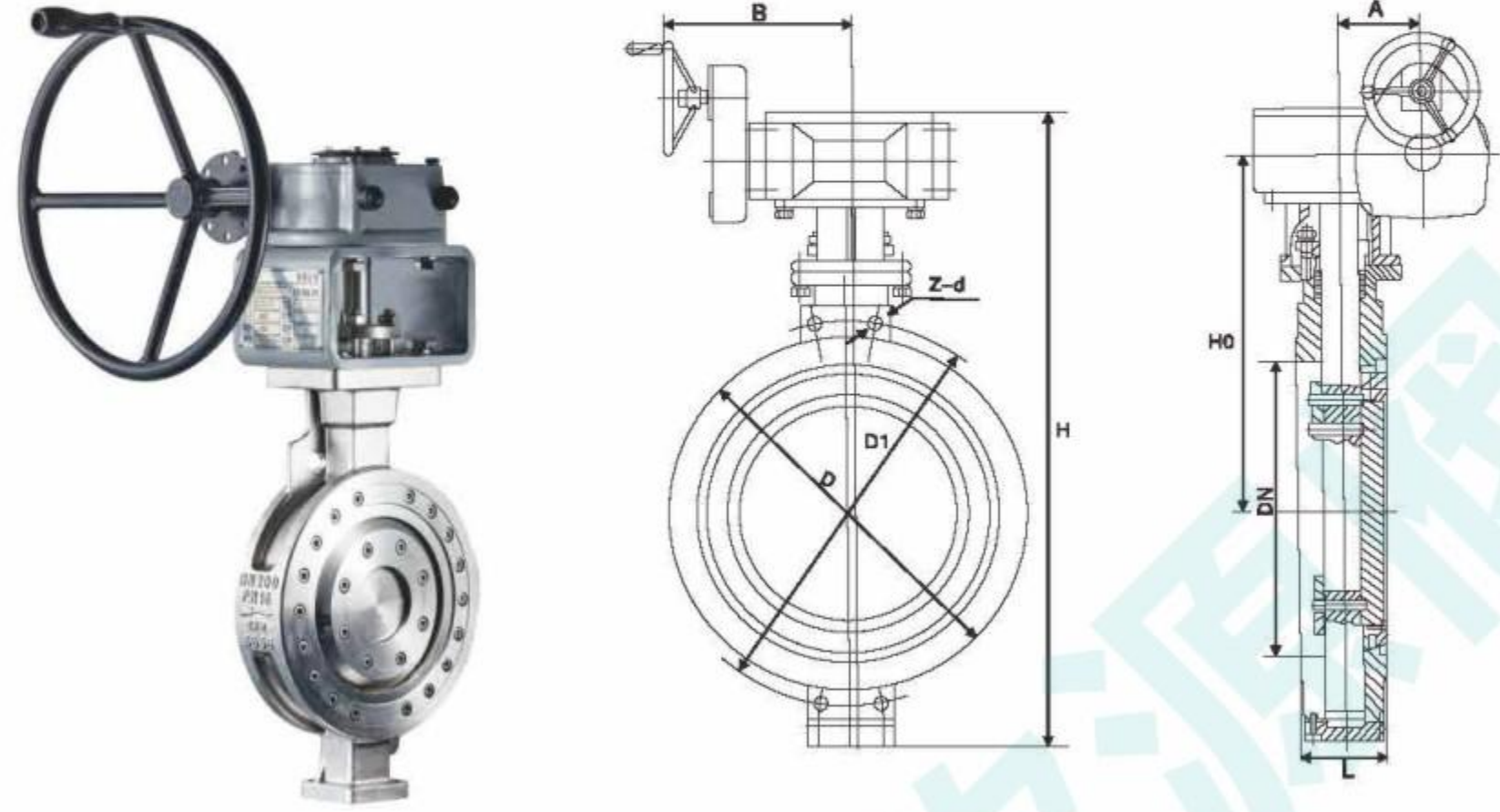

主要外形尺寸及连接尺寸 Main external and connection dimension

PN	标准值normal						参考值reference			
	DN	L	D	D1	Z-d	b	H	HO	A	B
1.0 Mpa	50	43	165	125	4-18	18	170	130	45	120
	65	46	185	145	8-18	18	170	145	45	120
	80	49	200	160	8-18	20	230	152	45	120
	100	56	220	180	8-18	20	320	192	45	120
	125	64	250	210	8-18	22	345	200	45	120
	150	70	285	240	8-22	22	385	230	66	150
	200	71	340	295	8-22	24	471	297	85	170
	250	76	395	350	12-22	26	533	327	85	170
	300	83	445	400	12-22	26	606	364	106	205
	350	92	505	460	16-22	26	694	404	106	205
400	102	565	515	16-26	26	757	444	130	240	
450	114	615	565	20-26	28	814	472	155	240	
500	127	670	620	20-26	28	902	522	169	306	
600	154	780	725	20-30	34	1048	590	198	324	
700	165	895	840	24-30	34	1277	810	220	335	
800	190	1015	950	24-33	36	1385	844	241	356	
900	203	1115	1050	28-33	38	1490	890	241	356	
1000	216	1230	1160	28-36	38	1620	950	241	356	
1.6 Mpa	50	43	165	125	4-18	18	170	130	45	120
	65	46	185	145	8-18	18	170	145	45	120
	80	49	200	160	8-18	20	230	152	45	120
	100	56	220	180	8-18	20	320	192	45	120
	125	64	250	210	8-18	22	345	200	45	120
	150	70	285	240	8-22	22	385	230	66	150
	200	71	340	295	12-22	24	471	297	85	170
	250	76	405	355	12-26	26	533	327	85	170
	300	83	460	410	12-26	28	606	364	106	205
	350	92	520	470	16-26	30	694	404	106	205
400	102	580	525	26-30	32	757	444	130	240	
450	114	640	585	20-30	40	814	472	155	240	
500	127	715	650	20-33	44	902	522	169	306	
600	154	840	770	20-36	54	1048	590	198	324	
700	165	910	840	24-36	42	1277	810	220	335	
800	190	1025	950	24-39	42	1385	844	241	356	
900	203	1125	1050	28-39	44	1490	890	241	356	
1000	216	1255	1170	28-42	46	1620	950	241	356	

主要连接尺寸 Main connection dimensions

PN	标准值normal						参考值reference			
	DN	L	D	D1	Z-d	b	H	HO	A	B
2.5 Mpa	50	43	165	125	4-18	20	170	130	45	120
	65	46	185	145	8-18	22	170	145	45	120
	80	49	200	160	8-18	24	310	233	206	90
	100	56	235	190	8-22	24	343	242	206	120
	125	64	270	220	8-26	26	385	254	206	120
	150	70	300	250	8-26	28	481	320	206	475
	200	71	360	310	12-26	30	547	355	442	610
	250	76	425	370	12-30	32	621	389	442	610
	300	83	465	430	16-30	34	653	423	558	670
	350	92	555	490	16-33	38	730	463	558	670
400	102	620	550	16-36	40	810	495	491	1120	
450	114	670	600	20-36	46	850	566	687	1120	
500	127	730	660	20-36	48	940	630	687	1120	
600	154	845	770	20-39	58	1150	727	710	1456	
700	165	960	875	24-42	50	1328	823	710	1456	
800	190	1085	990	24-48	54	1452	910	710	1456	
4.0 Mpa	50	43	165	125	4-18	20	/	/	/	/
	65	46	185	145	8-18	22	/	/	/	/
	80	49	200	160	8-18	24	/	/	/	/
	100	56	235	190	8-22	24	/	/	/	/
	125	64	270	220	8-26	26	/	/	/	/
	150	70	300	250	8-26	28	/	/	/	/
	200	71	375	320	12-30	34	/	/	/	/
	250	76	450	385	12-33	38	/	/	/	/
	300	83	515	450	16-33	42	/	/	/	/
	350	92	580	510	16-36	46	/	/	/	/
400	102	660	585	16-39	50	/	/	/	/	
450	114	685	610	20-39	57	/	/	/	/	
500	127	755	670	20-42	57	/	/	/	/	
600	154	890	795	20-48	72	/	/	/	/	
6.4 Mpa	50	43	180	135	4-22	26	/	/	/	/
	65	46	205	160	8-22	26	/	/	/	/
	80	49	215	170	8-22	28	/	/	/	/
	100	56	250	200	8-26	30	/	/	/	/
	125	64	295	240	8-30	34	/	/	/	/
	150	70	345	280	8-33	36	/	/	/	/
	200	71	415	345	12-36	42	/	/	/	/
	250	76	470	400	12-36	46	/	/	/	/
	300	83	530	460	16-36	52	/	/	/	/
	350	92	600	525	16-39	56	/	/	/	/
400	102	670	585	16-42	60	/	/	/	/	
10.0 Mpa	50	43	195	145	4-26	30	/	/	/	/
	65	46	220	170	8-26	34	/	/	/	/
	80	49	230	180	8-26	36	/	/	/	/
	100	56	265	210	8-30	40	/	/	/	/
	125	64	315	250	8-33	40	/	/	/	/
	150	70	355	290	12-33	44	/	/	/	/
	200	71	430	360	12-36	52	/	/	/	/
	250	76	505	430	12-39	60	/	/	/	/
	300	83	585	500	16-42	68	/	/	/	/
	350	92	655	560	16-48	74	/	/	/	/
400	102	715	620	16-48	78	/	/	/	/	

国标法兰蝶阀

GB flange butterfly valve

国标法兰蝶阀

GB flange butterfly valve

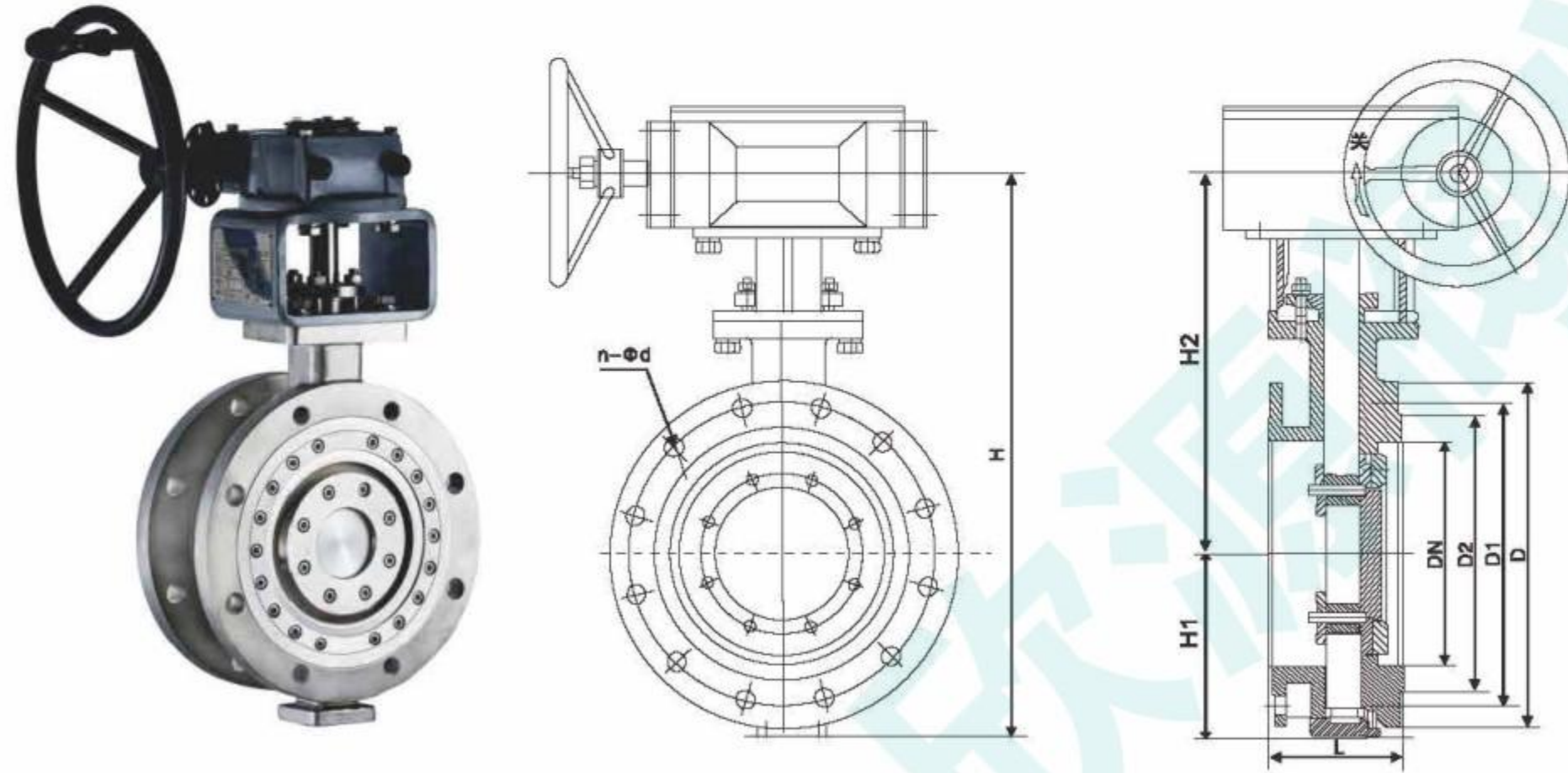

主要连接尺寸 Main connection dimensions

PN	DN	L	H1	H2	D	D1	D2	n-φd	PN	DN	L	H1	H2	D	D1	D2	n-φd
1.0 Mpa	50	108	85	196	165	125	102	4-18	1.6 Mpa	50	108	85	196	165	125	102	4-18
	65	112	90	211	185	145	122	4/8-18		65	112	90	211	185	145	122	4/8-18
	80	114	100	230	200	160	138	8-18		80	114	100	230	200	160	138	8-18
	100	127	107	256	220	180	158	8-18		100	127	107	256	220	180	158	8-18
	125	140	123	288	250	210	188	8-18		125	140	123	288	250	210	188	8-18
	150	140	140	315	285	240	212	8-22		150	140	140	315	285	240	212	8-22
	200	152	180	350	340	295	268	8-22		200	152	180	350	340	295	268	12-22
	250	165	200	398	395	350	320	12-22		250	165	200	398	405	355	320	12-26
	300	178	250	431	445	400	370	12-22		300	178	250	431	460	410	378	12-26
	350	190	270	478	505	460	430	16-22		350	190	270	478	520	470	428	16-26
	400	216	350	513	565	515	482	16-26		400	216	350	513	580	525	490	16-30
	450	222	365	550	615	565	532	20-26		450	222	365	550	640	585	550	20-30
	500	229	410	615	670	620	585	20-26		500	229	410	615	715	650	610	20-33
	600	267	470	670	780	725	685	20-30		600	267	470	670	840	770	725	20-36
	700	292	495	750	895	840	800	24-30		700	292	495	750	910	840	795	24-36
	800	318	575	820	1015	950	905	24-33		800	318	575	820	1025	950	900	24-39
900	330	620	895	1115	1050	1005	28-33	900	330	620	895	1125	1050	1000	28-39		
1000	410	680	990	1230	1160	1110	28-36	1000	410	680	990	1255	1170	1115	28-42		
1200	470	790	1150	1455	1380	1330	32-39	1200	470	790	1150	1485	1390	1330	32-48		
1400	530	870	1260	1675	1590	1535	36-42	1400	530	870	1260	1685	1590	1530	36-48		
1600	600	1010	1380	1915	1820	1760	40-48	1600	600	1010	1380	1930	1820	1750	40-56		
1800	670	1100	1500	2115	2020	1960	44-48	1800	670	1100	1500	2130	2020	1950	44-56		
2000	760	1200	1600	2325	2230	2170	48-48	2000	760	1200	1600	2345	2230	2150	48-62		

注：可根据ANSI、JIS、DIN标准及非标尺寸生产。
Note: according to ANSI、JIS、DIN standards and production of non-standard size.

主要连接尺寸 Main connection dimensions

PN	DN	标准值normal							参考值reference			
		L	D	D1	D2	Z-d	b	f	H	HO	A	B
2.5 Mpa	50	108	165	125	102	4-18	20	2	170	130	45	120
	65	112	185	145	122	8-18	22	2	265	210	35	90
	80	114	200	160	138	8-18	24	2	310	233	35	90
	100	127	235	190	162	8-22	24	2	343	242	45	120
	125	140	270	220	188	8-26	26	2	385	254	45	120
	150	140	300	250	218	8-26	28	2	445	580	66	150
	200	152	360	310	285	12-26	30	2	510	297	85	170
	250	165	425	370	345	12-30	32	2	569	339	85	170
	300	178	485	430	410	16-30	34	2	653	375	106	205
	350	190	555	490	465	16-33	38	2	730	420	106	205
	400	216	620	550	535	16-36	40	2	810	463	130	240
	450	222	670	600	560	20-36	46	2	850	495	155	240
	500	229	730	660	615	20-36	48	2	940	566	169	306
	600	267	845	770	735	20-39	58	2	1150	630	198	324
	700	292	960	875	820	24-42	50	5	1195	727	220	335
	800	318	1085	990	930	24-48	54	5	1268	810	45	356
4.0 Mpa	50	108	165	125	102	4-18	20	2	170	130	35	120
	65	112	185	145	122	8-18	22	2	265	210	35	90
	80	114	200	160	138	8-18	20	2	310	233	35	90
	100	127	235	190	162	8-22	24	2	343	242	45	120
	125	140	270	220	188	8-26	26	2	385	254	45	120
	150	140	300	250	218	8-26	28	2	445	280	66	150
	200	152	375	320	285	12-30	34	2	510	297	85	170
	250	165	450	385	345	12-33	38	2	569	339	85	170
	300	178	515	450	410	16-33	42	2	653	375	106	205
	350	190	580	510	465	16-36	46	2	730	420	106	205
	400	216	660	585	535	16-39	50	2	810	463	130	240
	450	222	685	610	560	20-39	57	2	850	495	155	240
	500	229	755	670	615	20-42	57	2	940	566	169	306
	600	267	890	795	735	20-48	72	2	1150	630	198	324
	700	292	995	900	820	24-54	68	5	1195	727	220	335
	800	318	1035	1030	930	24-58	76	5	1268	810	241	356

注：可根据ANSI、JIS、DIN标准及非标尺寸生产。
Note: according to ANSI、JIS、DIN standards and production of non-standard size.

国标法兰蝶阀

GB flange butterfly valve

API

美标法兰蝶阀

API Flange Butterfly Valve

主要连接尺寸 Main connection dimensions

PN	标准值normal								参考值reference			
	DN	L	D	D1	D2	Z-d	b	f	H	HO	A	B
6.4 Mpa	50	108	180	135	102	4-22	26	3	-	-	-	-
	65	112	205	160	122	8-22	26	3	-	-	-	-
	80	114	215	170	138	8-22	28	3	-	-	-	-
	100	127	250	200	162	8-26	30	3	-	-	-	-
	125	140	295	240	188	8-30	34	3	-	-	-	-
	150	140	345	280	218	8-33	36	3	-	-	-	-
	200	152	415	345	285	12-36	42	3	-	-	-	-
	250	165	470	400	345	12-36	46	3	-	-	-	-
	300	178	530	460	410	16-36	52	3	-	-	-	-
	350	190	600	525	465	16-39	56	3	-	-	-	-
	400	216	670	585	535	16-42	60	4	-	-	-	-
	450	222	-	-	-	-	-	-	-	-	-	-
	500	229	-	-	-	-	-	-	-	-	-	-
	600	267	-	-	-	-	-	-	-	-	-	-
	700	292	-	-	-	-	-	-	-	-	-	-
	800	318	-	-	-	-	-	-	-	-	-	-
10.0 Mpa	50	108	195	145	102	4-26	30	3	-	-	-	-
	65	112	220	170	122	8-26	34	3	-	-	-	-
	80	114	230	180	138	8-26	36	3	-	-	-	-
	100	127	265	210	162	8-30	40	3	-	-	-	-
	125	140	315	250	188	8-33	40	3	-	-	-	-
	150	140	355	290	218	12-33	44	3	-	-	-	-
	200	152	430	360	285	12-36	52	3	-	-	-	-
	250	165	505	430	345	12-39	60	3	-	-	-	-
	300	178	585	500	410	16-42	68	3	-	-	-	-
	350	190	655	560	465	16-48	74	4	-	-	-	-
	400	216	715	620	-	16-48	-	-	-	-	-	-
	450	222	-	-	-	-	-	-	-	-	-	-
	500	229	-	-	-	-	-	-	-	-	-	-
	600	267	-	-	-	-	-	-	-	-	-	-
	700	292	-	-	-	-	-	-	-	-	-	-
	800	318	-	-	-	-	-	-	-	-	-	-

注：可根据ANSI、JIS、DIN标准及非标尺寸生产。
Note: according to ANSI、JIS、DIN standards and production of non-standard size.

美标三偏心蝶阀几何图 American standard Butterfly Valve Geometric Graph

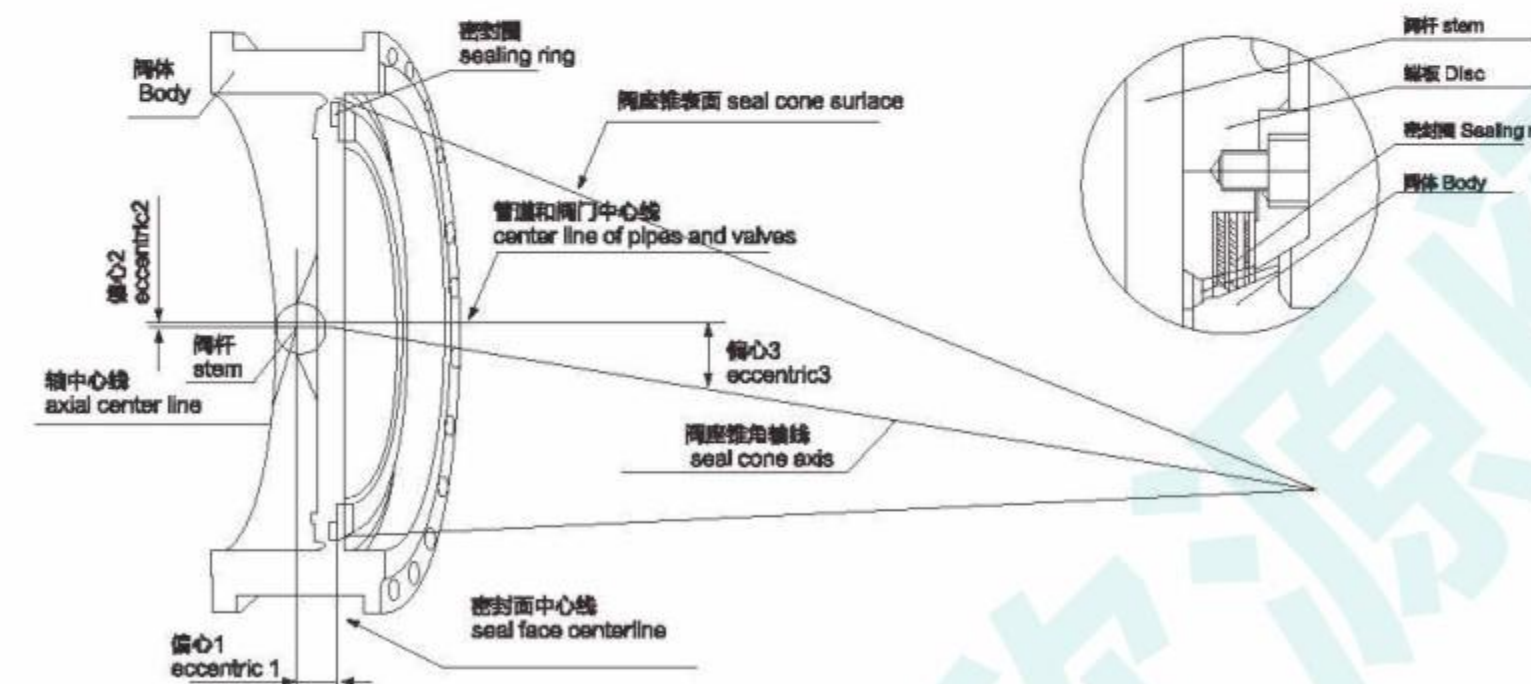

第一个偏心轴偏离密封面中心线
第二个偏心轴偏离管路及阀门中心线
第三个其独特的偏心阀座斜锥角与管路中心的夹角，这样，使得阀座与密封圈在门整个开关过程中完全脱离。这种结构即利用了凸轮效应。又完全消除了摩擦，去除了磨损和泄露的可能。

Firstly: The eccentric shaft deflected from the center line of sealing surface
Secondly: The eccentric shaft deflected from pipe and center line of valve.
Thirdly: The unique design of eccentric seat oblique cone and the angle of centerline, makes the seat and sealing ring completely out from the door during the open and close. This structure adopted the cam effect, completely eliminating the friction, avoiding the possibility of wear and leakage.

我公司生产的三偏心蝶阀，依靠安装在蝶板上的复合不锈钢密封圈来实现真正的零泄漏。

Our triple eccentric butterfly valve realizes zero leakage relying on the composite stainless steel sealing ring installed in the disc.

零泄漏是通过蝶板上密封圈的弹性来实现的，该密封圈的弹性是通过其径向的压缩和柔动生产的。密封圈与阀座接触面为斜锥面。密封圈与阀座之间的接触角产生轻微的“楔式效应”使密封圈发生柔动和径向压缩。正由于阀座与密封圈之间均匀接触以及密封圈的柔性，使得加载在阀座上的载荷均匀，从而用最小的扭矩实现最严密的切断。扭矩产生的弹性使得阀门严密关闭，而与介质流向或介质力无关。

Zero leakage is implemented by the elastic sealing ring mounted on the disc. The elasticity of sealing ring is produced by its radial compression and flexibility. The contact surface between the sealing ring and seat is an oblique cone. The contact angle between them gives slight "wedge effect", making the sealing ring producing flexibility and radial compression. The even contact between the seat and sealina ring, and the elasticity of sealing makes the load on the seat even, thus to perform closest cut off by the lowest torque. The elasticity produced by the torque makes the valve closely cut off, regardless of the flow direction or pressure of medium.



美标法兰蝶阀

API Flange Butterfly Valve

美标法兰蝶阀

API Flange Butterfly Valve

用途及特点 Purpose and Characteristic

复合金属密封圈的弹性特性使得阀门具有零泄漏性能。

扭矩密封确保阀门持续的零泄漏特性。

直角旋转无摩擦设计是通过一个独特的三偏心原理来实现的，它消除了90°开关旋转中阀座与密封圈之间的摩擦。

STL一体式硬面阀座可满足许多工况要求，使用寿命，维修方便。

一体式铸造(板焊)阀体，结构长度符合ISO5752、ASME16.10和API609,可替换高性能蝶阀以及其他种类的阀门，安装简单。灵活全金属结构加上零泄漏性能，使阀门具有“本质防火安全”特性。

阀杆防吹出设计安全可靠，完全符合API609的要求。

阀杆上的阀位指示器以及顶部安装法兰有利于蝶板位置指示。

美标三偏心蝶阀的阀杆采用一根通轴式结构，阀杆与蝶阀连接采用键或销键组合。

Elastic property of composite metal sealing ring performs zero leakage.

The torque seal ensures constant zero leakage characteristics of the valve.

The design of right-angled rotation with zero friction is implemented by the distinctive triple eccentric principle: it eliminates the friction between the seat and sealing ring in 90° rotation.

STL one-piece hard-surface seat may adapt to many working conditions, which is featured with long service life and easy maintenance.

One-piece cast (sheet welded) body, face to face dimensions conforming to ISO5752, ASME16.10 and API609, replacement of high performance butterfly valves and other types of valves, easy and flexible installation, intrinsic fireproof property thanks to all metal structure and leak tight performance.

Anti-blowout stem designs for high dependability, completely conforming to API609.

The valve position indicator on the stem and the flange mounted at the top of are in the favor of the indication of disc position.

The stem of American standard triple eccentric butterfly valve, is a shaft structure, stem and disc are connected by key or pin-key combination.

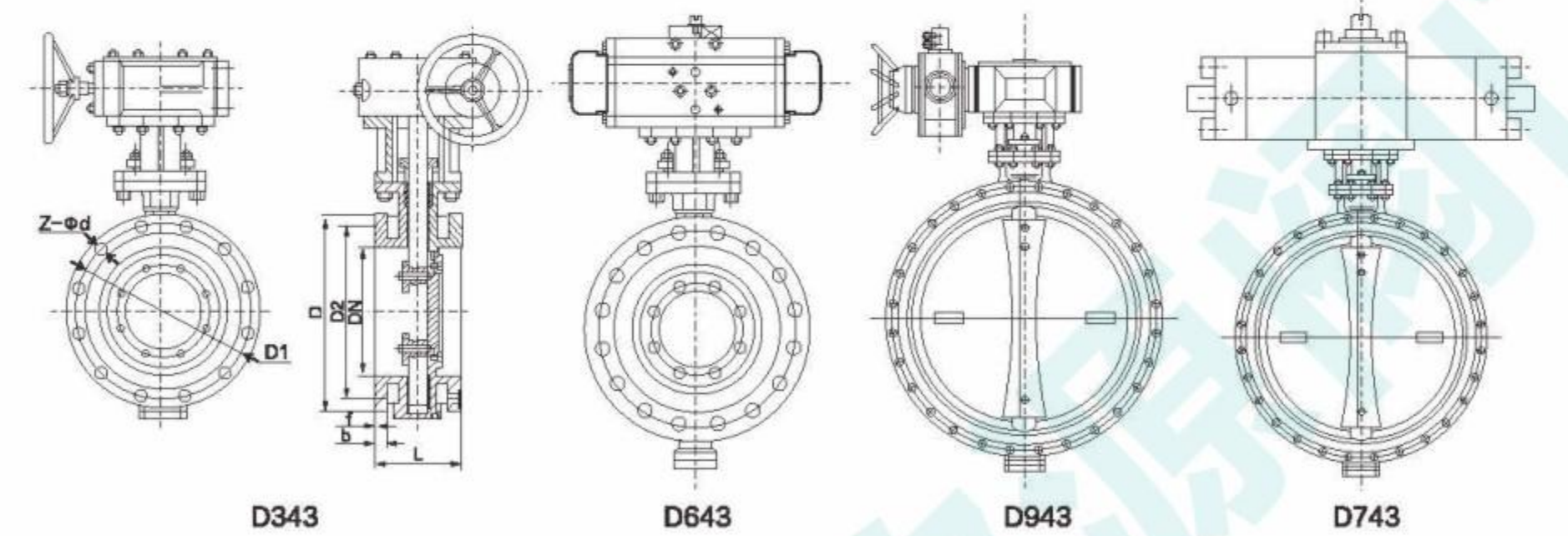

采用标准Adoption Standard

设计标准 Design Standard		API609			
法兰连接尺寸 Flange Connection Dimension		ASME B16.5 ASME B16.47			
试验和检验 Test and Inspection		API609			
温压等级 Pressure-Temperature Rate		ASME B 16.34			
结构长度Face to Face Dimension		API 609 ISO5752			
防火制造 Fire Safe		API 607			
压力等级Pressure Rating		150LB	300LB	600LB	900LB
常温试验压力(Mpa) Test Pressure at Room Temperature	壳体试验 Shell Test	3.0	7.5	16.5	22.5
	高压密封 High Pressure Seal Test	2.2	5.5	12.1	16.5
	低压密封 Low Pressure Seal Test	0.6	0.6	0.6	0.6
适用介质 Applicable Medium		水、油、气及各类腐蚀性介质(不同的介质选用不同的材质) Water, Oil, Gas and Other Causticity Media (Different Media Use Different Materials)			
适用温度Applicable Temperature		-100°C~800°C(不同的工况温度选用不同的材质) (Different Raw Material for Different Work Temperature)			

主要技术参数 Main Technology Parameter

公称压力 Nominal Pressure (MPa)	试验压力(MPa)Test Pressure			适用温度 Applicable Temperature	适用介质 Applicable Media	驱动形式 Operation
	壳体试验 Shell Test	高压密封 High Pressure Seal	低压密封 Low Pressure Seal			
Class150	3.0	2.2	0.6	碳钢 Carbon steel: -29°C~425°C 不锈钢 Stainless Steel: -100°C~800°C	空气、水、蒸气、 煤气、油品以及 酸、碱、盐带有 弱腐蚀性介质等。 Air, Water, Steam Coal Gas, Oil and Acid, Alkali, Salt Corrosive Medium and so on	蜗杆蜗轮传动 气传动、电传动 液动传动 Lever Operator, Worm Gear Operator, Pneumatic Operator, Electric Operator, Hydraulic transmission
Class300	7.5	5.5	0.6			
Class600	16.5	12.1	0.6			
Class900	22.5	16.5	0.6			

主要零件材质 Material for main Parts

零件名称 Parts Name	材料 Material
阀体 Body	CF8, CF3, CF3M, CF8M, 2205, 2507, WC6, LCB, C95800等
蝶板 Disc	CF8, CF3, CF3M, CF8M, 2205, 2507, WC6, LCB, C95800等
密封圈 Sealing Ring	SS304+Graphite, SS304+STL, SS316+Graphite, SS316L+Graphite, SS316L+STL, S31803+Graphite, S31803+STL PTFE, RPTFE, PPL, EPDM, NBR等
阀杆 Stem	F304, F304L, F316, F316L, F51, F53, MonelK400/500, 17-4PH等
轴套 Bushing	SF-1, SF-1B, SS304, SS316, SS304+PTFE, SS316+PTFE等
填料 Packing	Graphite, PTFE, PPL等

美标法兰蝶阀

API Flange Butterfly Valve

美标对夹式蝶阀

API Wafer Butterfly Valve

主要连接尺寸 Main Connection Dimensions

ASME 16.5 单位: Unit:mm

Inch	mm	结构长度 Structural length		150Lb						300Lb						600Lb					
		L1	L2	D	D1	D2	b	f	Z-φd	D	D1	D2	b	f	Z-φd	D	D1	D2	b	f	Z-φd
2	50	108	150	150	120.7	92.1	19.5	2	4-φ19	165	127	92.1	22.7	2	8-φ19	165	127	92.1	32.4	7	8-φ19
2.5	65	112	170	180	139.7	104.8	22.7	2	4-φ19	190	149.2	104.8	25.9	2	8-φ22	190	149.2	104.8	35.6	7	8-φ22
3	80	114	180	190	152.4	127	24.3	2	4-φ19	210	168.3	127	29	2	8-φ22	210	168.3	127	38.8	7	8-φ22
4	100	127	190	230	190.5	157.2	24.3	2	8-φ19	255	200	157.2	32.2	2	8-φ22	275	215.9	157.2	45.1	7	8-φ25
5	125	140	200	255	215.9	185.7	24.3	2	8-φ22	280	235	185.7	35.4	2	8-φ22	330	266.7	185.7	51.5	7	8-φ29
6	150	140	210	280	241.3	215.9	25.9	2	8-φ22	320	269.9	215.9	37	2	12-φ22	355	292.1	215.9	54.7	7	12-φ29
8	200	152	230	345	298.5	269.9	29	2	8-φ22	380	330.2	269.9	41.7	2	12-φ25	420	349.2	269.9	62.6	7	12-φ32
10	250	165	250	405	362	323.8	30.6	2	12-φ25	445	387.4	323.8	48.1	2	16-φ29	510	431.8	323.8	70.5	7	16-φ35
12	300	178	270	485	431.8	381	32.2	2	12-φ25	520	4508	381	51.3	2	16-φ32	560	489	381	73.7	7	20-φ35
14	350	190	290	535	476.3	412.8	35.4	2	12-φ29	585	514.4	412.8	54.4	2	20-φ32	605	527	412.8	76.9	7	20-φ38
16	400	216	310	595	539.8	469.9	37	2	16-φ29	650	571.5	469.9	57.6	2	20-φ35	685	603.2	469.9	83.2	7	20-φ41
18	450	222	330	635	577.9	533.4	40.1	2	16-φ32	710	628.6	533.4	60.8	2	24-φ35	745	654	533.4	89.6	7	20-φ44
20	500	229	350	700	635	584.2	43.3	2	20-φ32	775	685.8	584.2	64	2	24-φ35	815	723.9	584.2	95.9	7	24-φ44
24	600	267	390	815	749.3	692.2	48.1	2	20-φ35	915	812.8	692.2	70.3	2	24-φ41	940	838.2	692.2	108.6	7	24-φ51

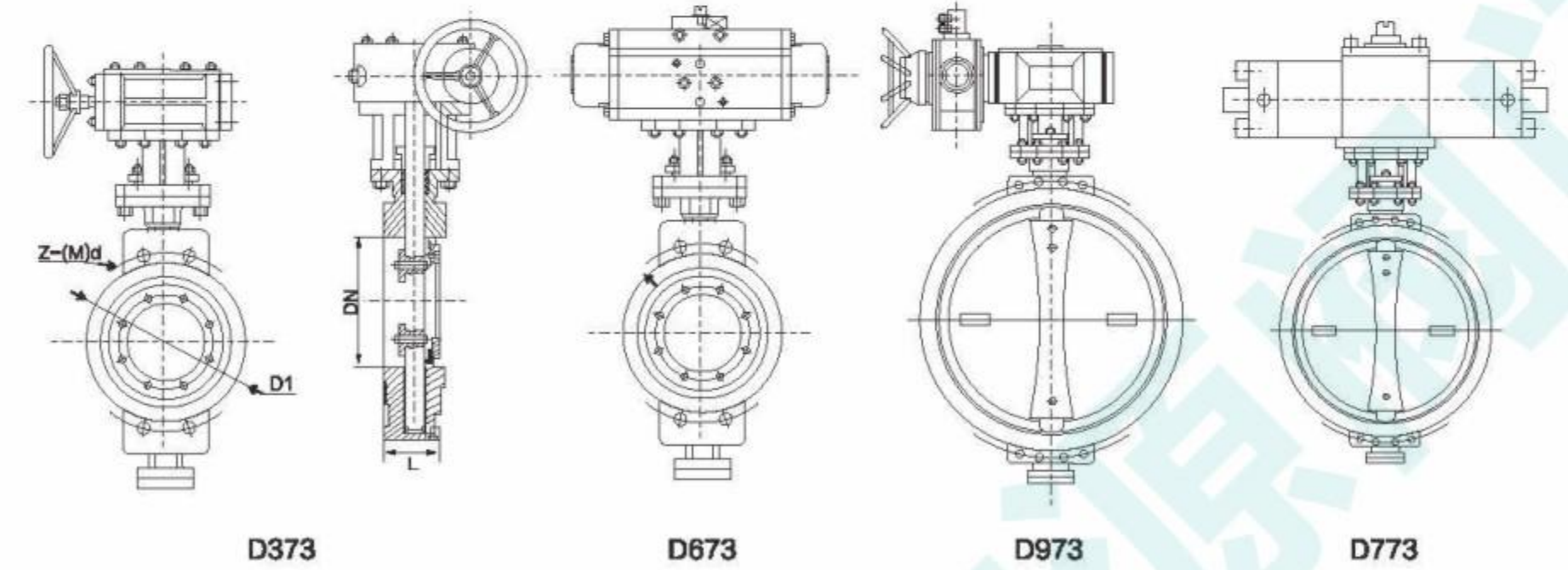

主要连接尺寸 Main Connection Dimensions

ASME B 16.47 series A 单位: Unit:mm

Inch	mm	结构长度 Structural length		150Lb						300Lb						600Lb					
		L1	L2	D	D1	D2	b	f	Z-φd	D	D1	D2	b	f	Z-φd	D	D1	D2	b	f	Z-φd
26	650	292	410	870	806.4	749	68.7	2	24-φ35	970	876.3	749	79.8	2	28-φ45	1015	914.4	749	115	7	28-φ51
28	700	292	430	925	863.6	800	71.9	2	28-φ35	1035	939.8	800	86.2	2	28-φ45	1075	965.2	800	118.2	7	28-φ54
30	750	318	450	985	914.4	857	75.1	2	28-φ35	1090	997	857	92.5	2	28-φ48	1130	1022.4	857	121.3	7	28-φ54
32	800	318	470	1060	977.9	914	81.4	2	28-φ41	1150	1054.1	914	98.9	2	28-φ51	1195	1079.5	914	124.5	7	28-φ61
36	900	330	510	1170	1085.8	1022	90.9	2	32-φ41	1270	1168.4	1022	105.2	2	32-φ54	1315	1193.8	1022	130.9	7	28-φ67
40	1000	410	550	1290	1200.2	1124	90.9	2	36-φ41	1240	1155.7	1086	114.8	2	32-φ45	1320	1212.8	1111	165.8	7	32-φ67
44	1100	410	550	1405	1314.4	1245	102.1	2	40-φ41	1355	1263.6	1194	124.3	2	32-φ48	1455	1333.5	1226	180.1	7	32-φ67
48	1200	470	630	1510	1422.4	1359	108.4	2	44-φ41	1465	1371.6	1302	133.8	2	32-φ51	1595	1460.5	1334	196	7	32-φ73
52	1300	470	630	1625	1536.7	1461	116.3	2	44-φ48	1580	1479.6	1410	144.9	2	32-φ54	1720	1574.8	1435	210.2	7	32-φ80
56	1400	530	710	1745	1651	1575	124.3	2	48-φ48	1710	1600.2	1518	154.4	2	28-φ61	1855	1695.4	1543	224.5	7	32-φ86
60	1500	530	710	1855	1759	1676	132.3	2	52-φ48	1810	1701.8	1626	164	2	32-φ61	1995	1822.4	1657	240.4	7	28-φ92

主要连接尺寸 Main Connection Dimensions

ASME B 16.47 series A 单位: Unit:mm

Inch	mm	结构长度 Structural length		150Lb						300Lb						600Lb					
		L1	L2	D	D1	D2	b	f	Z-φd	D	D1	D2	b	f	Z-φd	D	D1	D2	b	f	Z-φd
26	650	292	410	785	744.5	711	41.8	2	36-φ22	865	803.3	737	89.4	2	32-φ36	890	806.4	727	111.2	7	28-φ45
28	700	292	430	835	795.3	762	45	2	40-φ22	920	857.2	787	89.4	2	36-φ36	950	863.6	784	115.9	7	28-φ48
30	750	318	450	885	846.1	813	45	2	44-φ22	990	920.8	845	94.1	2	36-φ39	1020	927.1	841	125.5	7	28-φ51
32	800	318	470	940	900.1	864	46.6	2	48-φ22	1055	977.9	902	103.6	2	32-φ42	1085	984.2	895	130.2	7	28-φ54
36	900	330	510	1055	1009.6	972	52.9	2	44-φ25	1170	1089	1010	103.6	2	32-φ45	1215	1104.9	1010	146.1	7	28-φ60
40	1000	410	550	1175	1120.8	1080	56.1	2	44-φ28	1275	1190.6	1114	116.3	2	40-φ45						
44	1100	410	550	1275	1222.4	1181	60.9	2	52-φ28	1385	1295.4	1219	127.5	2	40-φ48						
48	1200	470	630	1390	1335.1	1289	65.6	2	44-φ32	1510	1416	1327	129	2	40-φ51						
52	1300	470	630	1495	1436.7	1391	70.4	2	52-φ32	1615	1517.6	1429	143.3	2	48-φ51						
56	1400	530	710	1600	1543	1492	73.6	2	60-φ32	1765	1651	1537	154.4	2	36-φ60						
60	1500	530	710	1725	1662.1	1600	76.7	2	52-φ35	1880	1763.7	1651	151.3	2	40-φ60						

主要技术参数 Main Technology Parameter

公称压力 Nominal Pressure (MPa)	试验压力(MPa) Test Pressure			适用温度 Applicable Temperature	适用介质 Applicable Media	驱动形式 Operation
	壳体试验 Shell Test	高压密封 High Pressure Seal	低压密封 Low Pressure Seal			
Class150	3.0	2.2	0.6	不锈钢 Stainless Steel -100°C~800°C	空气、水、蒸气、 煤气、油品以及 酸、碱、盐带有 弱腐蚀性介质等。	蜗杆蜗轮传动 气传动、电传动 液动传动 Lever Operator, Worm Gear Operator, Pneumatic Operator, Electric Operator, Hydraulic transmission
Class300	7.5	5.5	0.6			
Class600	16.5	12.1	0.6			
Class900	22.5	16.5	0.6			

主要零件材质 Material for main Parts

零件名称 Parts Name	材料 Material
阀体 Body	CF8,CF3,CF3M,CF8M,2205,2507,WC6,LCB, C95800等
蝶板 Disc	CF8,CF3,CF3M,CF8M,2205,2507,WC6,LCB, C95800等
密封圈 Sealing Ring	SS304+Graphite,SS304+STL, SS316+Graphite,SS316L+Graphite, SS316L+STL, S31803+Graphite, S31803+STL PTFE, RPTFE, PPL, EPDM, NBR等
阀杆 Stem	F6a,F304,F304L,F316,F316L,F51,F53,MonelK400/500, 17-4PH等
轴套 Bushing	SF-1,SF-1B,SS304,SS316,SS304+PTFE,SS316+PTFE等
填料 Packing	Graphite,PTFE,PPL等

美标对夹式蝶阀

API Wafer Butterfly Valve

美标凸耳式蝶阀

API Lug Butterfly Valve

主要连接尺寸 Main Connection Dimensions

ASME 16.5 单位: Unit:mm

直径 Diameter		150Lb				300Lb				600Lb			
Inch	mm	L1	D1	Z-Md	法兰螺孔数 Flange hole no	L1	D1	Z-Md	法兰螺孔数 Flange hole no	L1	D1	Z-Md	法兰螺孔数 Flange hole no
2	50	43	120.7	4-Φ19	4	43	127	4-(M5/8"-UNC11)	8	43	127	4-(M5/8"-UNC11)	8
2.5	65	46	139.7	4-Φ19	4	46	149.2	4-(M3/4"-UNC10)	8	46	149.2	4-(M3/4"-UNC10)	8
3	80	48	152.4	4-Φ19	4	48	168.3	4-(M3/4"-UNC10)	8	54	168.3	4-(M3/4"-UNC10)	8
4	100	54	190.5	4-Φ19	8	54	200	4-(M3/4"-UNC10)	8	64	215.9	4-(M7/8"-UNC9)	8
5	125	57	215.9	4-Φ22	8	59	235	4-(M3/4"-UNC10)	8	78	266.7	4-(M1"-UN8)	8
6	150	57	241.3	4-Φ22	8	59	269.9	4-(M3/4"-UNC10)	12	78	292.1	4-(M1"-UN8)	12
8	200	64	298.5	4-Φ22	8	73	330.2	4-(M7/8"-UNC9)	12	102	349.2	4-(M1½"-UN8)	12
10	250	71	362	4-Φ25	12	83	387.4	4-(M1"-UN8)	16	117	431.8	4-(M1½"-UN8)	16
12	300	81	431.8	4-Φ25	12	92	450.8	4-(M½"-UN8)	16	140	489	4-(M1½"-UN8)	20
14	350	92	476.3	4-Φ29	12	117	514.4	4-(M½"-UN8)	20	155	527	4-(M1½"-UN8)	20
16	400	102	539.8	4-(M1"-UN8)	16	133	571.5	4-(M½"-UN8)	20	178	603.2	4-(M1½"-UN8)	20
18	450	114	577.9	4-(M½"-UN8)	16	149	628.6	4-(M½"-UN8)	24	200	654	4-(M1½"-UN8)	20
20	500	127	635	4-(M½"-UN8)	20	159	685.8	4-(M½"-UN8)	24	216	723.9	4-(M1½"-UN8)	24
24	600	154	749.3	4-(M½"-UN8)	20	181	812.8	4-(M½"-UN8)	24	232	838.2	4-(M1½"-UN8)	24

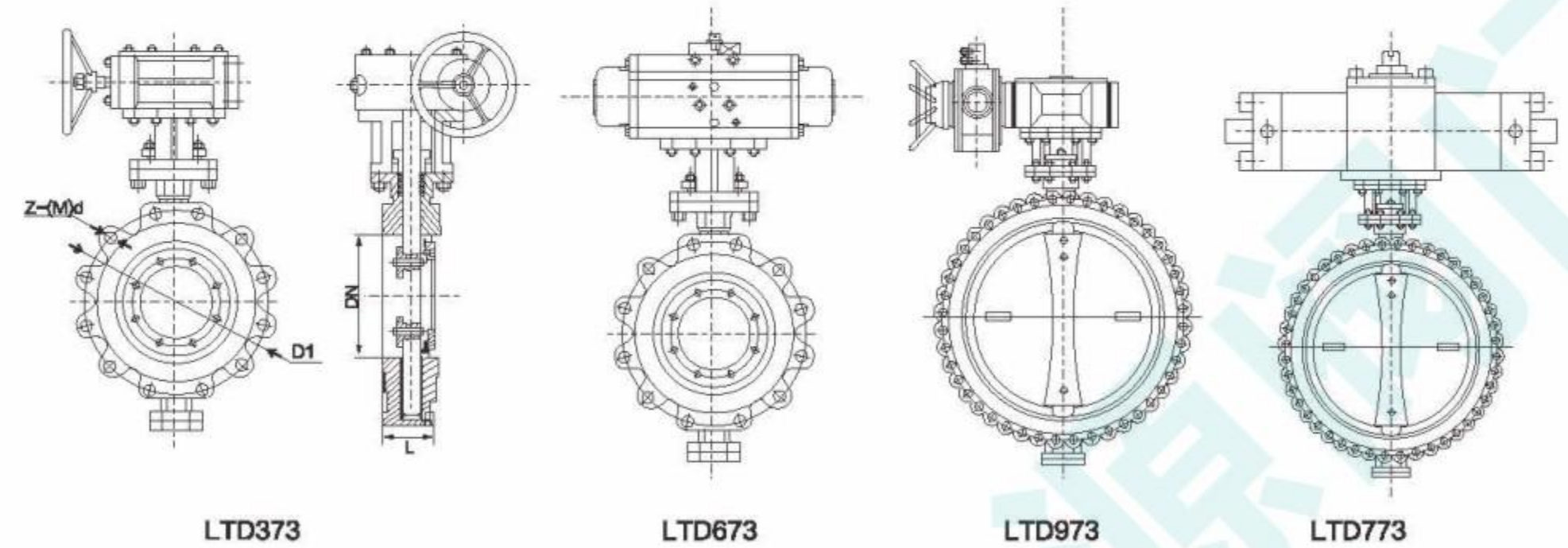

主要连接尺寸 Main Connection Dimensions

ASME B 16.47 Series A 单位: Unit:mm

直径 Diameter		150Lb				300Lb				600Lb			
Inch	mm	L1	D1	Z-Md	法兰螺孔数 Flange hole no	L1	D1	Z-Md	法兰螺孔数 Flange hole no	L1	D1	Z-Md	法兰螺孔数 Flange hole no
26	650	165	806.4	4-(M1½"-UN8)	24	229	876.3	4-(M1½"-UN8)	28	229	914.4	8-(M1½"-UN8)	28
28	700	165	863.6	4-(M1½"-UN8)	28	229	939.8	4-(M1½"-UN8)	28	229	965.2	8-(M2"-UN8)	28
30	750	190	914.4	4-(M1½"-UN8)	28	241	997	4-(M1½"-UN8)	28	241	1022.4	8-(M2"-UN8)	28
32	800	190	977.9	4-(M1½"-UN8)	28	241	1054.1	4-(M1½"-UN8)	28	241	1079.5	8-(M2½"-UN8)	28
36	900	203	1085.8	4-(M1½"-UN8)	32	241	1168.4	8-(M2"-UN8)	32	241	1193.8	8-(M2½"-UN8)	28
40	1000	216	1200.2	4-(M1½"-UN8)	36	330	1155.7	8-(M1½"-UN8)	32	330	1212.8	8-(M2½"-UN8)	32
44	1100	254	1314.4	4-(M1½"-UN8)	40	360	1263.6	8-(M1½"-UN8)	32	360	1333.5	8-(M2½"-UN8)	32
48	1200	254	1422.4	4-(M1½"-UN8)	44	360	1371.6	8-(M1½"-UN8)	32	360	1460.5	8-(M2½"-UN8)	32
52	1300	279	1536.7	4-(M1½"-UN8)	44	390	1479.6	8-(M2"-UN8)	32	390	1574.8	8-(M3"-UN8)	32
56	1400	279	1651	4-(M1½"-UN8)	48	390	1600.2	8-(M1½"-UN8)	28	390	1695.4	8-(M3½"-UN8)	32
60	1500	318	1759	4-(M1½"-UN8)	52	440	1701.8	8-(M1½"-UN8)	32	440	1822.4	8-(M3½"-UN8)	28

主要连接尺寸 Main Connection Dimensions

ASME B 16.47 Series B 单位: Unit:mm

直径 Diameter		150Lb				300Lb				600Lb			
Inch	mm	L1	D1	Z-Md	法兰螺孔数 Flange hole no	L1	D1	Z-Md	法兰螺孔数 Flange hole no	L1	D1	Z-Md	法兰螺孔数 Flange hole no
26	650	165	744.5	4-(M3/4"-UNC10)	36	229	803.3	8-(M1½"-UN8)	28	229	806.4	8-(M1½"-UN8)	28
28	700	165	795.3	4-(M3/4"-UNC10)	40	229	857.2	8-(M1½"-UN8)	28	229	863.6	8-(M1½"-UN8)	28
30	750	190	846.1	4-(M3/4"-UNC10)	44	241	920.8	8-(M1½"-UN8)	28	241	927.1	8-(M1½"-UN8)	28
32	800	190	900.1	8-(M3/4"-UNC10)	48	241	977.9	8-(M1½"-UN8)	28	241	984.2	8-(M2"-UN8)	28
36	900	203	1009.6	8-(M7/8"-UNC9)	44	241	1089	8-(M1½"-UN8)	32	241	1104.9	8-(M2½"-UN8)	28
40	1000	216	1120.8	8-(M1"-UN8)	44	330	1190.6	8-(M1½"-UN8)	32				
44	1100	254	1222.4	8-(M1"-UN8)	52	360	1295.4	8-(M1½"-UN8)	32				
48	1200	254	1335.1	8-(M1½"-UN8)	44	360	1416	8-(M1½"-UN8)	32				
52	1300	279	1436.7	8-(M1½"-UN8)	52	390	1517.6	8-(M1½"-UN8)	32				
56	1400	279	1543	8-(M1½"-UN8)	60	390	1651	8-(M2½"-UN8)	28				
60	1500	318	1662.1	8-(M1½"-UN8)	52	440	1763.7	8-(M2½"-UN8)	32				

主要技术参数 Main Technology Parameter

公称压力 Nominal Pressure (MPa)	试验压力(MPa) Test Pressure			适用温度 Applicable Temperature	适用介质 Applicable Media	驱动形式 Operation
	壳体试验 Shell Test	高压密封 High Pressure Seal	低压密封 Low Pressure Seal			
Class150	3.0	2.2	0.6	不锈钢 Stainless Steel: -100℃~800℃	空气、水、蒸气、油、酸、碱、盐、腐蚀性介质等。 Air, Water, Steam, Coal Gas, Oil and Acid, Alkali, Salt Corrosive Medium and so on	蜗杆蜗轮传动、气传动、电传动、液动传动 Lever Operator, Worm Gear Operator, Pneumatic Operator, Electric Operator, Hydraulic transmission
Class300	7.5	5.5	0.6			
Class600	16.5	12.1	0.6			
Class900	22.5	16.5	0.6			

主要零件材质 Material for main Parts

零件名称 Parts Name	材料 Material
阀体 Body	WCB, CF8, CF3, CF3M, CF8M, 2205, 2507, WC6, LCB, C95800等
蝶板 Disc	WCB, CF8, CF3, CF3M, CF8M, 2205, 2507, WC6, LCB, C95800等
密封圈 Sealing Ring	SS304+Graphite, SS304+STL, SS316+Graphite, SS316L+Graphite, SS316L+STL, S31803+Graphite, S31803+STL PTFE, RPTFE, PPL, EPDM, NBR等
阀杆 Stem	F6a, F304, F304L, F316, F316L, F51, F53, Monel K400/500, 17-4PH等
轴套 Bushing	SF-1, SF-1B, SS304, SS316, SS304+PTFE, SS316+PTFE等
填料 Packing	Graphite, PTFE, PPL等

美标凸耳式蝶阀

API Lug Butterfly Valve

对焊式三偏心多层次硬密封蝶阀

Butt welding type three eccentric multi-level hard seal butterfly valves

主要连接尺寸Main Connection Dimensions

ASME 16.5

通径Diameter		150Lb			300Lb			600Lb		
Inch	mm	L1	D1	Z-Md	L1	D1	Z-Md	L1	D1	Z-Md
2	50	43	120.7	4-(M5/8"-UNC11)	43	127	8-(M5/8"-UNC11)	43	127	8-(M5/8"-UNC11)
2.5	65	46	139.7	4-(M5/8"-UNC11)	46	149.2	8-(M3/4"-UNC10)	46	149.2	8-(M3/4"-UNC10)
3	80	48	152.4	4-(M5/8"-UNC11)	48	168.3	8-(M3/4"-UNC10)	54	168.3	8-(M3/4"-UNC10)
4	100	54	190.5	8-(M5/8"-UNC11)	54	200	8-(M3/4"-UNC10)	64	215.9	8-(M7/8"-UNC9)
5	125	57	215.9	8-(M3/4"-UNC10)	59	235	8-(M3/4"-UNC10)	78	266.7	8-(M1"-UN8)
6	150	57	241.3	8-(M3/4"-UNC10)	59	269.9	12-(M3/4"-UNC10)	78	292.1	12-(M1 1/2"-UN8)
8	200	64	298.5	8-(M3/4"-UNC10)	73	330.2	12-(M7/8"-UNC9)	102	349.2	12-(M1 1/2"-UN8)
10	250	71	362	12-(M7/8"-UNC9)	83	387.4	16-(M1"-UN8)	117	431.8	16-(M1 1/2"-UN8)
12	300	81	431.8	12-(M7/8"-UNC9)	92	450.8	16-(M3/4"-UN8)	140	489	20-(M1 1/4"-UN8)
14	350	92	476.3	12-(M1"-UNC8)	117	514.4	20-(M3/4"-UN8)	155	527	20-(M1 1/2"-UN8)
16	400	102	539.8	16-(M1"-UN8)	133	571.5	20-(M3/4"-UN8)	178	603.2	20-(M1 1/2"-UN8)
18	450	114	577.9	16-(M1 1/2"-UN8)	149	628.6	24-(M3/4"-UN8)	200	654	20-(M1 1/2"-UN8)
20	500	127	635	20-(M1 1/2"-UN8)	159	685.8	24-(M3/4"-UN8)	216	723.9	24-(M1 1/2"-UN8)
24	600	154	749.3	20-(M1 1/2"-UN8)	181	812.8	24-(M3/4"-UN8)	232	838.2	24-(M1 1/2"-UN8)

主要连接尺寸Main Connection Dimensions

ASME B 16.47

通径Diameter		150Lb			300Lb			600Lb		
Inch	mm	L1	D1	Z-Md	L1	D1	Z-Md	L1	D1	Z-Md
26	650	165	806.4	24-(M1 1/4"-UN8)	229	876.3	28-(M1 1/2"-UN8)	229	914.4	28-(M1 1/2"-UN8)
28	700	165	863.6	28-(M1 1/4"-UN8)	229	939.8	28-(M1 1/2"-UN8)	229	965.2	28-(M2"-UN8)
30	750	190	914.4	28-(M1 1/4"-UN8)	241	997	28-(M1 1/2"-UN8)	241	1022.4	28-(M2"-UN8)
32	800	190	977.9	28-(M1 1/2"-UN8)	241	1054.1	28-(M1 1/2"-UN8)	241	1079.5	28-(M2 1/4"-UN8)
36	900	203	1085.8	32-(M1 1/2"-UN8)	241	1168.4	32-(M2"-UN8)	241	1193.8	28-(M2 1/2"-UN8)
40	1000	216	1200.2	36-(M1 1/2"-UN8)	330	1155.7	32-(M1 1/2"-UN8)	330	1212.8	32-(M2 1/4"-UN8)
44	1100	254	1314.4	40-(M1 1/2"-UN8)	360	1263.6	32-(M1 1/4"-UN8)	360	1333.5	32-(M2 1/2"-UN8)
48	1200	254	1422.4	44-(M1 1/2"-UN8)	360	1371.6	32-(M1 1/2"-UN8)	360	1460.5	32-(M2 3/4"-UN8)
52	1300	279	1536.7	44-(M1 1/4"-UN8)	390	1479.6	32-(M2"-UN8)	390	1574.8	32-(M3"-UN8)
56	1400	279	1651	48-(M1 1/4"-UN8)	390	1600.2	28-(M2 1/4"-UN8)	390	1695.4	32-(M3 1/4"-UN8)
60	1500	318	1759	52-(M1 1/4"-UN8)	440	1701.8	32-(M2 3/4"-UN8)	440	1822.4	28-(M3 1/2"-UN8)

主要连接尺寸Main Connection Dimensions

ASME B 16.47

通径Diameter		150Lb			300Lb			600Lb		
Inch	mm	L1	D1	Z-Md	L1	D1	Z-Md	L1	D1	Z-Md
26	650	165	744.5	36-(M3/4"-UNC10)	229	803.3	32-(M1 1/4"-UN8)	229	806.4	28-(M1 1/2"-UN8)
28	700	165	795.3	40-(M3/4"-UNC10)	229	857.2	36-(M1 1/4"-UN8)	229	863.6	28-(M1 1/2"-UN8)
30	750	190	846.1	44-(M3/4"-UNC10)	241	920.8	36-(M1 1/2"-UN8)	241	927.1	28-(M1 1/2"-UN8)
32	800	190	900.1	48-(M3/4"-UNC10)	241	977.9	32-(M1 1/2"-UN8)	241	984.2	28-(M2"-UN8)
36	900	203	1009.6	44-(M7/8"-UNC9)	241	1089	32-(M1 1/2"-UN8)	241	1104.9	28-(M2 1/4"-UN8)
40	1000	216	1120.8	44-(M1"-UN8)	330	1190.6	40-(M1 1/2"-UN8)			
44	1100	254	1222.4	52-(M1"-UN8)	360	1295.4	40-(M1 1/4"-UN8)			
48	1200	254	1335.1	44-(M1 1/2"-UN8)	360	1416	40-(M1 1/2"-UN8)			
52	1300	279	1436.7	52-(M1 1/2"-UN8)	390	1517.6	48-(M1 1/2"-UN8)			
56	1400	279	1543	60-(M1 1/2"-UN8)	390	1651	36-(M2 1/4"-UN8)			
60	1500	318	1662.1	52-(M1 1/4"-UN8)	440	1763.7	40-(M2 1/4"-UN8)			

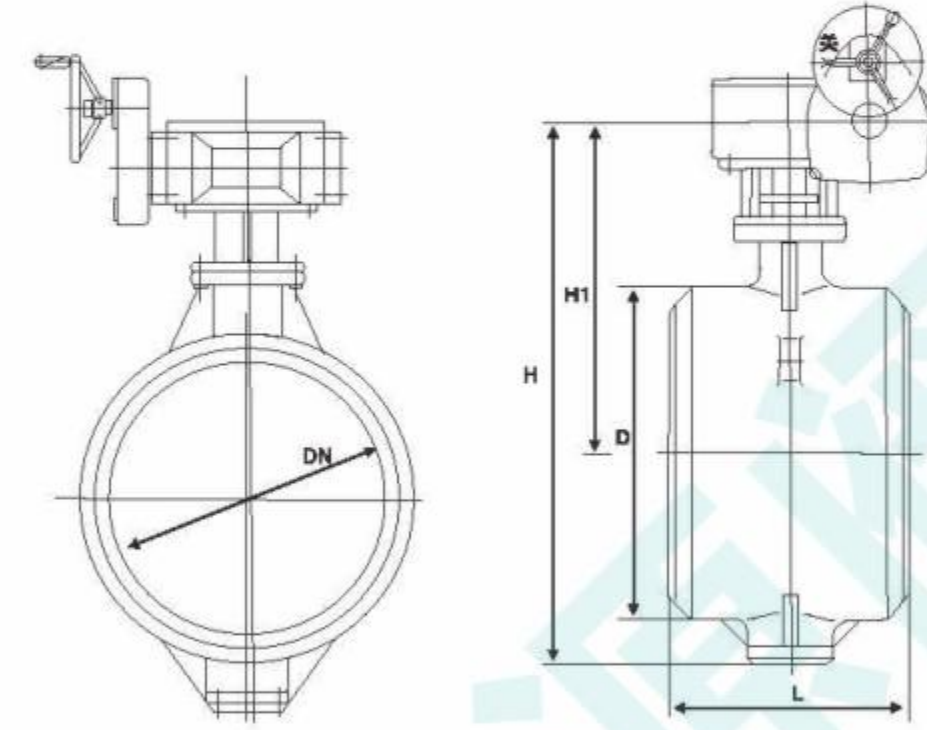

主要性能规范Main performance standard

公称压力 PN(MPa)	强度试验 Strength test (MPa)	密封试验 Seal test (Mpa)	适用温度(°C) Suitable temperature	适用介质 Applicable medium
1.0	1.5	1.1	≤425°C	水、蒸气、煤气、油品、热空气、天然气等介质 Water, steam, gas, oil, hot air, natural gas and other media
1.6	2.4	1.76		
2.5	3.8	2.75		
4.0	6.0	4.4		

主要零件材质Main part materials

阀体、蝶板 Valve body, butterfly plate	阀杆Stem	密封环Ring	填料 packing
铸钢、铸不锈钢 Cast steel, cast stainless steel	不锈钢stainless steel	不锈钢+石墨片 Stainless steel + graphite sheet	柔性石墨 Flexible Graphite

主要连接尺寸 Main connection dimensions

公称通径 DN(mm)	L	1.0MPa		1.6MPa		2.5MPa		4.0MPa	
		H1	H	H1	H	H1	H	H1	H
100	190	280	390	280	390	280	390	280	390
125	200	300	420	300	420	300	420	300	420
150	210	320	460	320	460	320	460	320	460
200	230	370	550	370	550	370	550	370	550
250	250	420	620	420	620	420	620	420	620
300	270	500	750	500	750	500	750	500	750
350	290	530	800	530	800	530	800	530	800
400	310	570	870	570	870	570	870	570	870
450	330	600	920	600	920	600	920	600	920
500	350	680	1040	680	1040	680	1040	680	1040
600	390	750	1190	750	1190	750	1190	750	1190
700	430	810	1290	810	1290	810	1290	/	/
800	470	905	1440	905	1440	905	1440	/	/
900	510	960	1550	960	1550	960	1550	/	/
1000	550	1010	1650	1010	1650	1010	1650	/	/
1200	630	1175	1920	1175	1920	1175	1920	/	/
1400	710	1310	2170	1310	2170	/	/	/	/
1600	790	1460	2440	1460	2440	/	/	/	/
1800	870	1560	2650	1560	2650	/	/	/	/
2000	950	1670	2860	1670	2860	/	/	/	/

法兰式/对夹式双向金属硬密封蝶阀

Flanged/clip-on butterfly valve with double metal hard seal

用途Uses

本蝶阀系吸收、消化国外技术，采用三维偏心多层次金属密封结构，适用介质温度≤600℃冶金、电力、石油化工、空气、煤气、可燃气体，以及给排水等介质管道上作调节流量和截断流体的最佳装置。

特点Feature

本双向蝶阀采取多层次三偏心金属硬密封结构，不仅具有普通多层次三偏心金属硬密封蝶阀的全部优良性能，由于在设计上合理地减小了径向偏心率，在关闭状态下阀杆所受受力矩较小，处于静平衡，同时，蝶板密封圈采用了优质碳素材料和高韧性不锈钢组成多层次结构，不仅柔中有刚能与阀座保持最佳密封，而且具有非常好的自动补偿功能，特别在较大温差的工况条件下，可以消除由此引起的结构变形对密封性能的影响，又由于在加工和装配过程采用了预应力方法，使阀门在反向受压时产生的相对位移得到充分补偿，因此本蝶阀不论正向或反向受压，均能在额定压差下达到泄漏量为零。

标准与规范Standards and norms

设计与制造 Design and Manufacture	结构长度 Structure Length	压力-温度等级 Pressure - temperature rating	连接法兰 Connection flange	试验与检验 Test and Inspection
GB/T 12238 JB/T 8527	GB/T 12221	GB/T 12224	HG 20592-20635 HG/T 20592	GB/T 26480

主要性能规范Main performance standard

公称直径Nominal size	DN(mm)	50~2000				50~500
公称压力 Nominal Pressure	PN(MPa)	0.6	1.0	1.6	2.5	4.0
试验压力 Test Pressure	强度试验Strength test	0.9	1.5	2.4	3.75	6.0
	密封试验Seal test	0.66	1.1	1.76	2.75	4.4
	气密封试验Gas seal test	0.6	0.6	0.6	0.6	0.6
泄漏率Leakage	<0.1xDNmm ³ /s(符合GB/T13927-92标准) <0.1xDNmm ³ /s(in line with GB/T13927-92 standard)					
适用温度 Suitable temperature	碳钢: -29°C~425°C; 不锈钢、铬钼钢: -40°C ~550°C Carbon steel: -29°C~425°C, stainless steel, chrome molybdenum steel: -40°C ~550°C					
适用介质 Applicable medium	空气、水、蒸气、煤气、油品以及酸、碱、盐带有弱腐蚀性介质等 Air, water, steam, gas, oil and acid, alkali, salt with a weak corrosive media, etc.					
驱动形式 Drive Type	蜗杆蜗轮传动、电传动 Worm worn transmission, electric transmission					

主要零件材质Main part materials

零件名称Part name	材料 Material	零件名称Part name	材料 Material
阀体Body	碳钢、不锈钢、铬钼钢、合金钢 Carbon steel, stainless steel, chrome molybdenum steel, alloy steel	阀杆Stem	2Cr13、1Cr13不锈钢、铬钼钢 2Cr13/1Cr13 stainless steel, chrome molybdenum steel
蝶板Disc	碳钢、合金钢、不锈钢、铬钼钢 Carbon steel, alloy steel, stainless steel, chrome molybdenum steel	轴承 Bearing	奥氏体不锈钢、304氮化 Austenitic stainless steel, 304 nitride
密封圈Ring	不锈钢与耐高温石墨片组合成多层次 Stainless steel and high temperature graphite sheet to form a multi-level	填料 packing	柔性石墨 Flexible graphite

法兰式/对夹式双向金属硬密封蝶阀

Flanged/clip-on butterfly valve with double metal hard seal

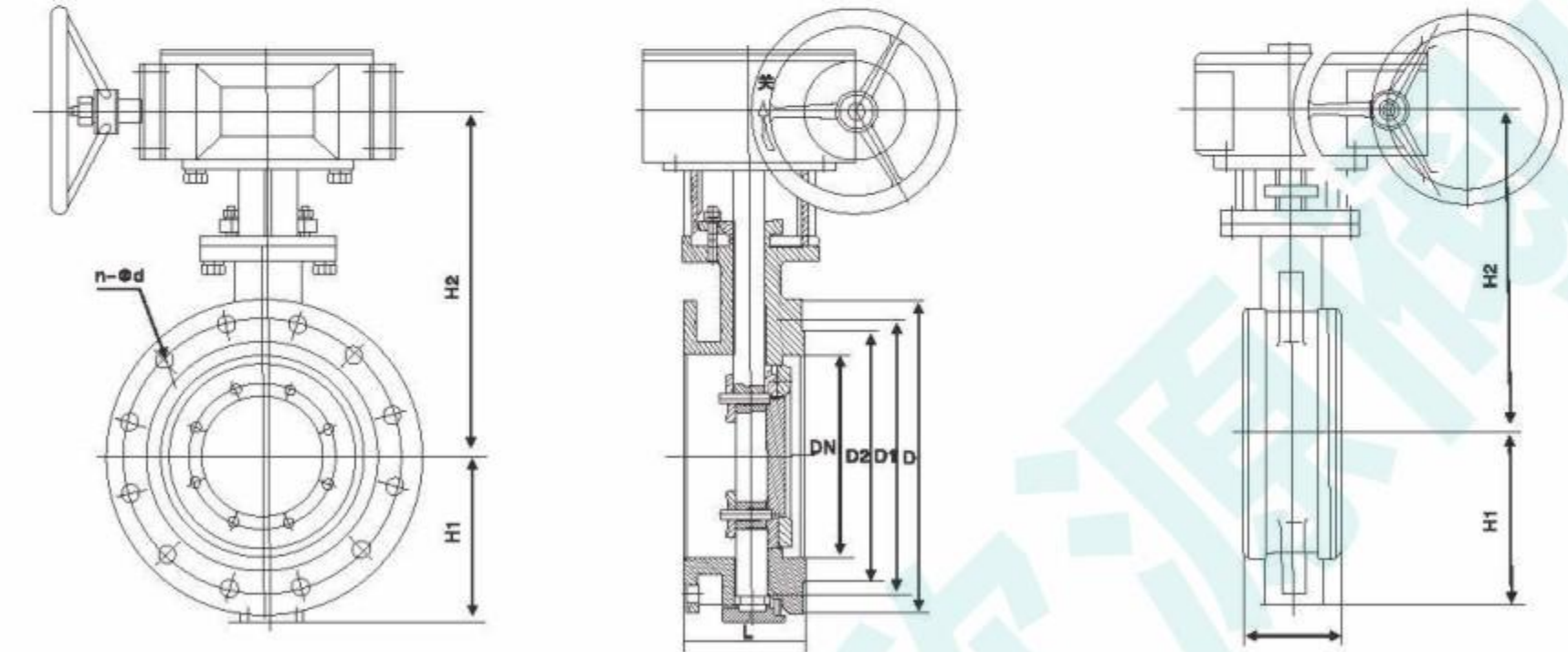

主要连接尺寸 Main connection dimensions

公称口径 DN(mm)	主要尺寸 Main dimensions				法兰尺寸和螺栓规格 Flange dimensions and bolt specifications							
	L	L1	H2	H1	0.6MPa				1.0MPa			
					D	D1	D2	n-φd	D	D1	D2	n-φd
100	127	56	285	107	210	170	144	4-19	220	180	156	8-18
125	140	64	300	123	240	200	174	8-19	250	210	184	8-18
150	140	70	320	140	265	225	199	8-19	285	240	211	8-22
200	152	71	370	180	320	280	254	8-19	340	295	266	8-22
250	165	76	420	200	375	335	309	12-19	395	350	310	12-22
300	178	83	500	250	440	395	363	12-23	445	400	370	12-22
350	190	92	530	270	490	445	413	12-23	505	460	429	16-22
400	216	102	570	300	540	495	463	16-23	565	515	480	16-26
450	222	114	600	320	595	550	518	16-23	615	565	530	20-26
500	229	127	680	360	645	600	568	20-23	670	620	582	20-26
600	267	154	750	420	755	705	667	20-26	780	725	682	20-30
700	292	165	810	480	860	810	772	24-26	895	840	794	24-30
800	318	190	905	540	975	920	878	24-31	1015	950	901	24-33
900	330	203	960	590	1075	1020	978	24-31	1115	1050	1001	28-33
1000	410	216	1010	640	1175	1120	1078	28-31	1230	1160	1112	28-36
1200	470	254	1175	750	1405	1340	1295	32-34	1455	1380	1328	32-39
1400	530	/	1310	860	1630	1560	1510	36-37	1675	1590	1530	36-42
1600	600	/	1460	980	1830	1760	1710	40-37	1915	1820	1750	40-48
1800	670	/	1560	1090	2045	1970	1918	44-40	2115	2020	/	44-48
2000	760	/	1670	1190	2265	2180	2125	48-43	2325	2230	/	48-48

注: 可根据ANSI、JIS、DIN标准及非标尺寸生产。
Note: according to ANSI、JIS、DIN standards and production of non-standard size.

法兰式/对夹式双向金属硬密封蝶阀

Flanged/clip-on butterfly valve with double metal hard seal

多偏心金属密封蝶阀

Multi-eccentric metal seal butterfly valve

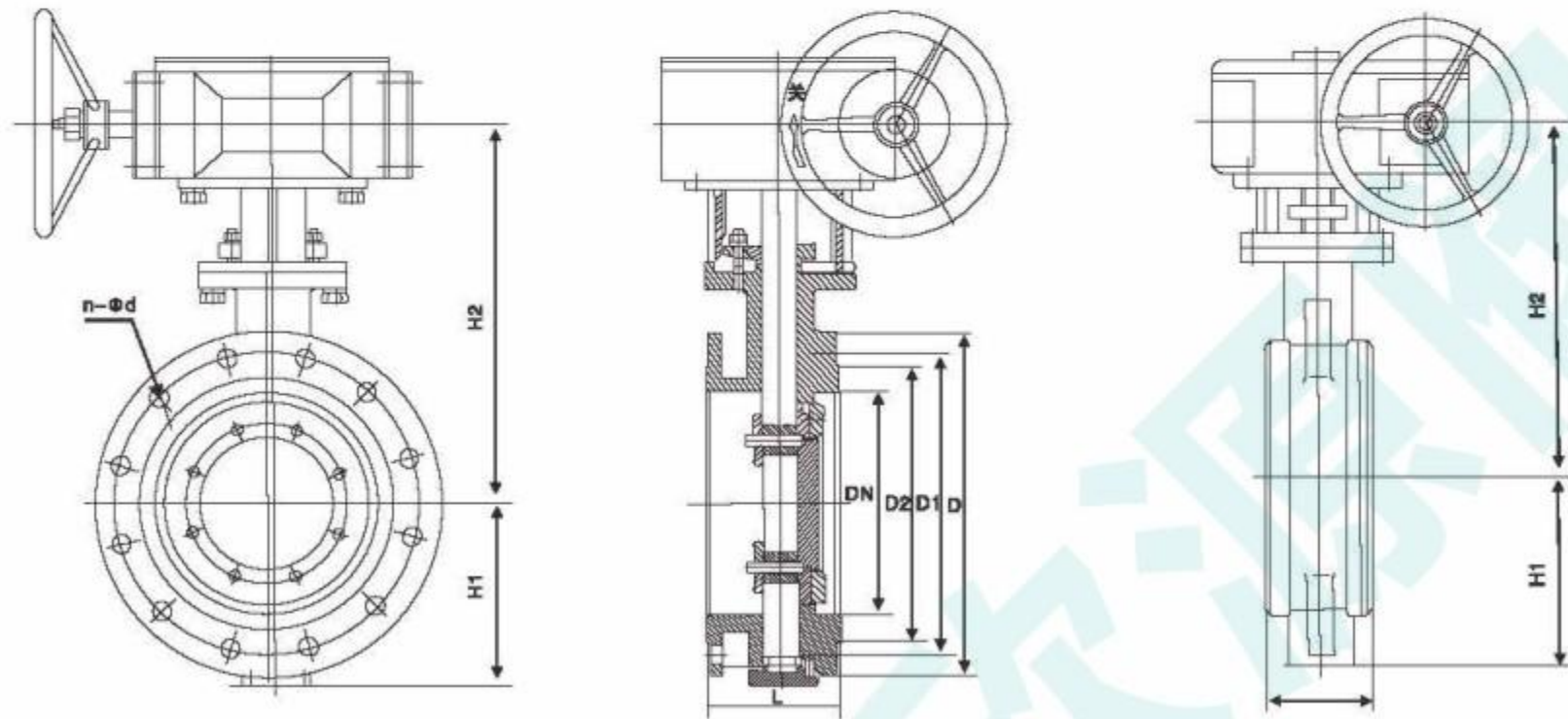

主要连接尺寸 Main connection dimensions

公称口径 DN(mm)	主要尺寸 Main dimensions				法兰尺寸和螺栓规格 Flange dimensions and bolt specifications							
	L	L1	H2	H1	1.6MPa				2.5MPa			
					D	D1	D2	n-φd	D	D1	D2	n-φd
100	127	56	285	107	220	180	156	8-18	235	190	156	8-22
125	140	64	300	123	250	210	184	8-18	270	220	184	8-26
150	140	70	320	140	285	240	211	8-22	300	250	211	8-26
200	152	71	370	180	340	295	266	12-22	360	310	274	12-26
250	165	76	420	200	405	355	319	12-26	425	370	330	12-30
300	178	83	500	250	460	410	370	12-26	485	430	389	16-30
350	190	92	530	270	520	470	429	16-26	555	490	448	16-33
400	216	102	570	300	580	525	480	16-30	620	550	503	16-36
450	222	114	600	320	640	585	548	20-30	670	600	548	20-36
500	229	127	680	360	715	650	609	20-33	730	660	609	20-36
600	267	154	750	420	840	770	720	20-36	845	770	720	20-39
700	292	165	810	480	910	840	794	24-36	960	875	820	24-42
800	318	190	905	540	1025	950	901	24-39	1085	990	928	24-48
900	330	203	960	590	1125	1050	1001	28-39	1185	1090	/	28-48
1000	410	216	1010	640	1255	1170	1112	28-42	1320	1210	/	28-55
1200	470	254	1175	750	1485	1390	1328	32-48	1530	1420	/	32-55

注: 可根据ANSI、JIS、DIN标准及非标尺寸生产。
Note: according to ANSI、JIS、DIN standards and production of non-standard size.

轴向密封

- * 阀门采用密封柔性石墨填料并采用碟形弹簧预紧装置, 在填料长期使用密封性能下降起到自动调整轴向密封比压, 保证轴向密封无泄露。
- * 在逸散性介质的工况下可采用低泄露碳纤维碗型结合填料结构, 达到ISO 15848和API622标准规定要求。
- * 双组填料中间增加隔环, 根据需要隔环处可增加引漏装置, 可应用在真空系统和蒸汽系统等高要求场合达到可靠的密封。

Axial Seal

The valve adopts the sealing flexible graphite packing and the dish spring pre-tightening device, and automatically adjusts the axial seal specific pressure to ensure the axial seal without leakage during the long term use of the packing.
* Low-leakage CFRP bowl-type combined packing structure can be used in the case of fugitive media to meet the requirements of ISO 15848 and API622 standards.
* A double packing ring is added in the middle of the packing, and a leak-inducing device can be added to the ring according to the need, which can be used to achieve reliable sealing in high requirements such as vacuum system and steam system.

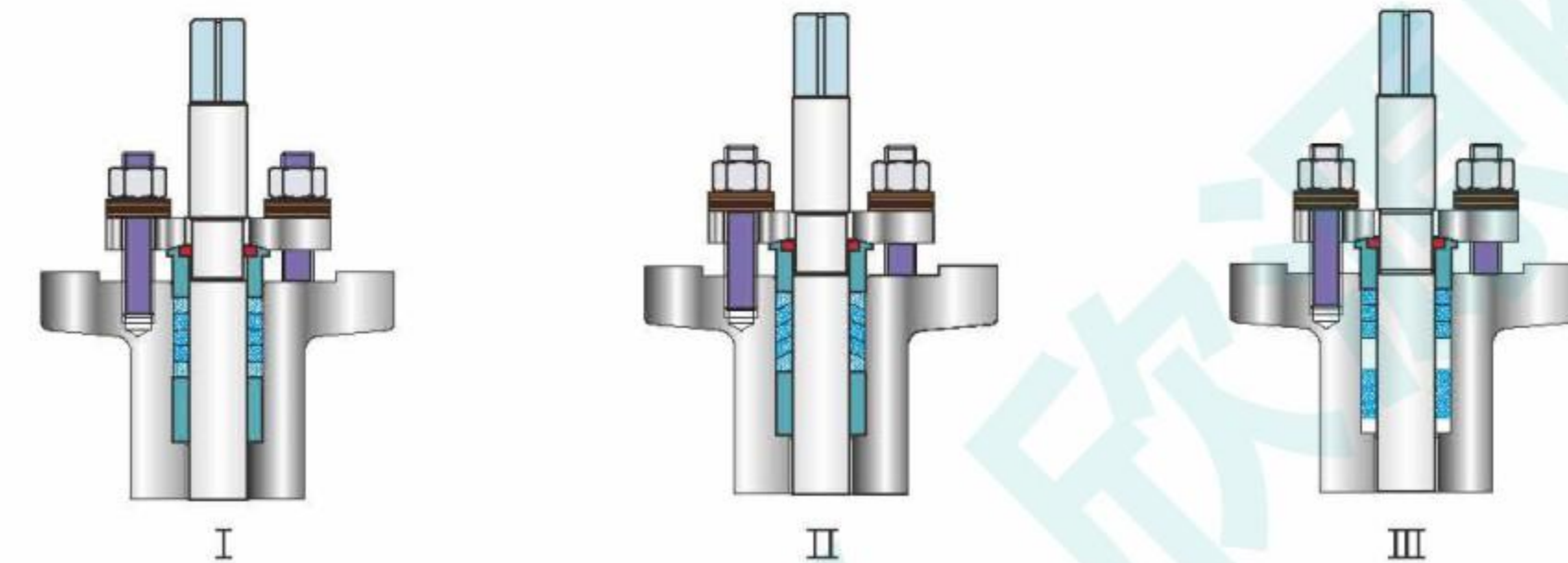

阀轴系统

采用17-4PH, XM-19或双相钢的高强度阀杆配合自润滑轴承和奥氏体铸铁轴承, 摩擦系数低, 并避免了阀门长期使用后产生卡滞、擦伤等问题。此外, 轴承内端被加长, 以提供对阀杆的最大支撑, 这样大大提高了阀门寿命和操作性能。

Spindle system

High strength stem with 17-4 PH, XM-19 or duplex steel combined with self-lubricating bearing and austenitic cast iron bearing has low friction coefficient and avoids the problems of sticking and scratching after long-term use of valve. In addition, the inner end of the bearing is lengthened to provide maximum support to the stem, which greatly improves valve life and operating performance.

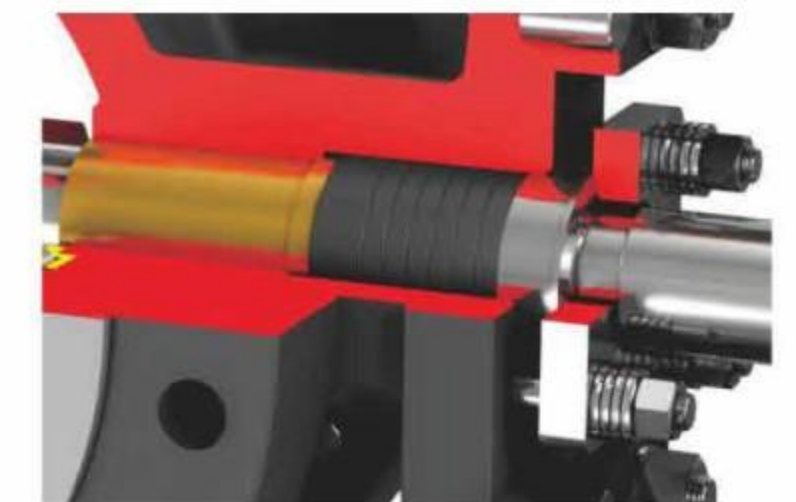

防飞出设计

蝶阀标配有防吹出阀杆设计, 在阀杆填料外部有一个最小截面沟槽并放置一个对开环, 底部的也有一个阀杆固定环, 这二部分结构的双重保护, 阀杆内部和连接强度高于压力边界外10%, 完全防止阀杆在发生意外断裂的情况下射出, 避免出现安全事故, 符合API609标准要求。

Anti ejection Design

Butterfly valve standard with anti-blow stem design, outside the stem packing with a minimum cross-section groove and placed a pair of open-loop, the bottom also has a stem fixed ring, these two parts of the structure of dual protection, stem internal and connection strength is higher than 10% outside the pressure boundary, completely prevent the stem from ejection in the event of accidental fracture, avoid safety accidents, meet the API609 standard requirements.

防火功能

蝶阀密封副采用金属对金属全硬密封设计, 防火是固有功能特性, 符合ISO10497和API607标准要求。

Fire resistant

butterfly valve seal pair adopts metal to metal full hard seal design, fire protection is inherent functional characteristics, meet the requirements of ISO10497 and API607 standards.

多偏心金属密封蝶阀

Multi-eccentric metal seal butterfly valve

产品分解图 Product Decomposition

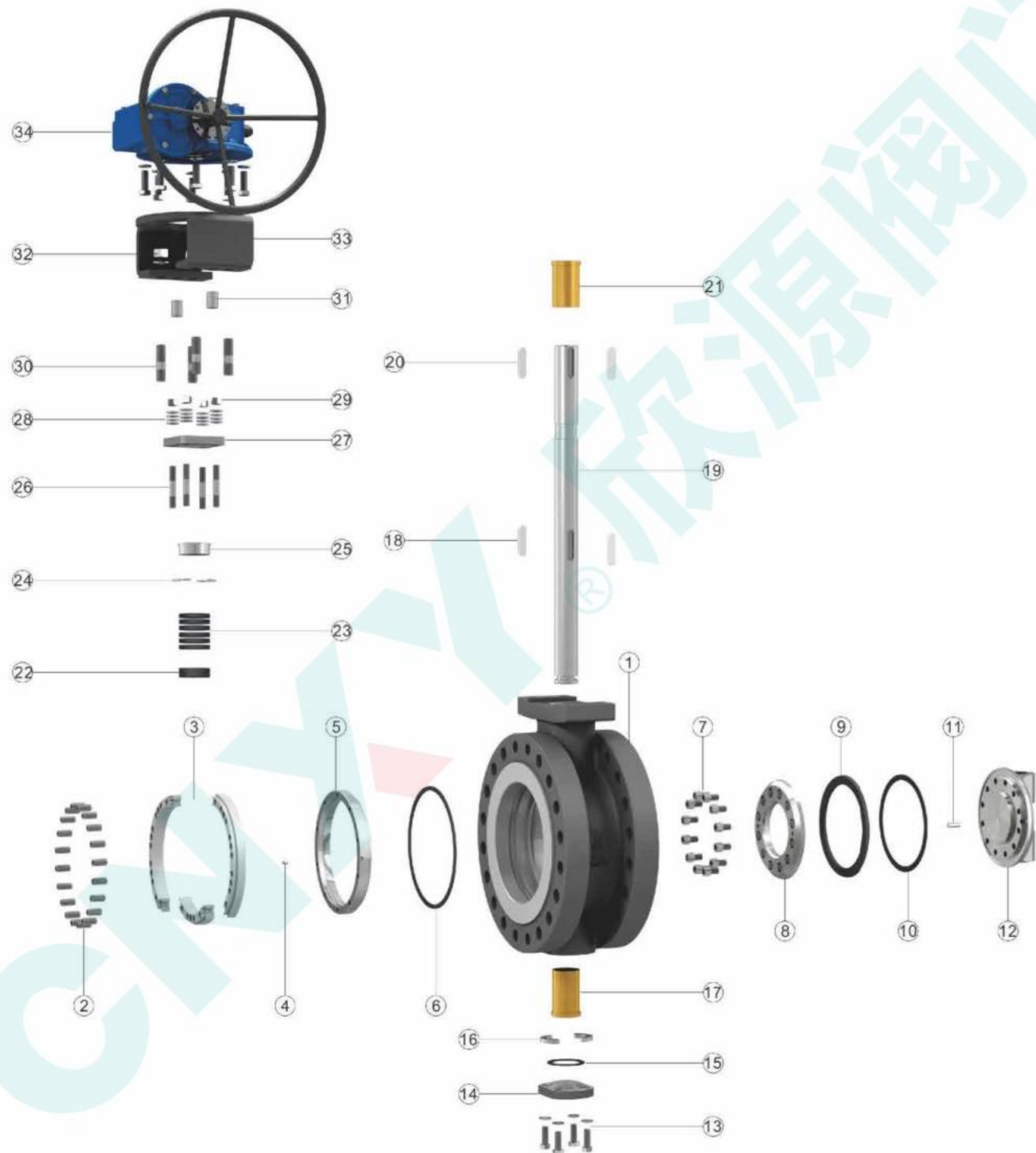

法兰式 Flange Type

多偏心金属密封蝶阀

Multi-eccentric metal seal butterfly valve

产品零件清单 Product Parts List

No	部件名称 Spare Part Name	阀体材料组别 Valve body material group			
		WCB	LCB	CF8	CF8M
1	阀体Body	WCB	LCB	CF8	CF8M
2	紧定螺钉Holding screw	8.8	A2-70	A2-70	A4-70
3	三开压环Pressure rings	A105	LF1	CF8	CF8M
4	阀座定位销Pin	SS304	SS304	SS304	SS316
5	阀座环Seat ring	SS410硬化 SS304+STL	SS410硬化 SS304+STL	F51(S31803) SS304+STL	F51(S31803) SS316+STL
6	阀座垫片Seat gasket	SS304+石墨Graphite	SS304+石墨Graphite	SS304+石墨Graphite	SS316+石墨Graphite
7	内六角螺钉Screw	8.8级	8.8级	A2-70	A4-70
8	密封压板Sealing press	A105	A105	SS304	SS316
9	密封环Gasket ring	SS420+石墨Graphite SS420硬化 SS304+STL	SS420+石墨Graphite SS420硬化 SS304+STL	SS304+柔性石墨 SS304硬化 SS304+STL	SS316+柔性石墨 SS316硬化 SS316+STL
10	密封垫片Gasket seal	SS304+石墨Graphite	SS304+石墨Graphite	SS304+柔性石墨	SS316+柔性石墨
11	密封环定位销Pin	SS304	SS304	SS304	SS316
12	阀板Disc	WCB	LCB	CF8	CF8M
13	六角螺栓Bolts	8.8	8.8	A2-70	A4-70
14	阀底盖Bottom cover	WCB	LCB	CF8	CF8M
15	密封垫片Gasket seal	SS304+石墨Graphite	SS304+石墨Graphite	SS304+石墨Graphite	SS304+石墨Graphite
16	对开环Split collar	SS410	SS410	SS304	SS304
17	轴套Shaft sleeve	SF-1	SF-1	SF-1S	SF-1SS
18	平键key	A439 D2 45	A439 D2 45	A439 D2 SS304	A439 D2 SS316
19	阀杆Shaft	SS410	SS410	17-4PH	17-4PH/XM19
20	平键Key	45	45	45	45
21	轴套Shaft sleeve	SF-1 A439 D2	SF-1 A439 D2	SF-1S A439 D2	SF-1SS A439 D2
22	填料垫Packing gasket	Ss410	SS410	Ss304	SS316
23	填料Packing	Graphite	Graphite	Graphite	Graphite
24	防飞环Fly-proof ring	SS304	SS304	SS304	SS304
25	填料压套Packing gland	SS410	SS410	SS304	SS316
26	螺柱Bolt	A2-70	A2-70	A2-70	A4-70
27	填料压盖Packing gland	WCB	LCB	CF8	CF8
28	碟形弹簧Belleville spring	SS304	SS304	SS304	SS304
29	螺母Nut	A2-70	A2-70	A2-70	A2-70
30	螺柱Double srew bolt	6.8	6.8	6.8	6.8
31	定位销Locating pin	45	45	45	45
32	螺母Nut	6	6	6	6
33	支架Support	WCB	WCB	WCB	WCB
34	执行器Actuator	---	---	---	---

***需要特殊的阀体和内部零件材料: 如双相不锈钢, 蒙乃尔合金, 哈氏合金, 铜合金等特殊材料, 请联系我们的销售工程师
 Special valve body and internal parts materials are needed: such as duplex stainless steel, Monel alloy, Hastelloy, copper alloy and other special materials, please contact our Sales Engineer

多偏心金属密封蝶阀

Multi-eccentric metal seal butterfly valve

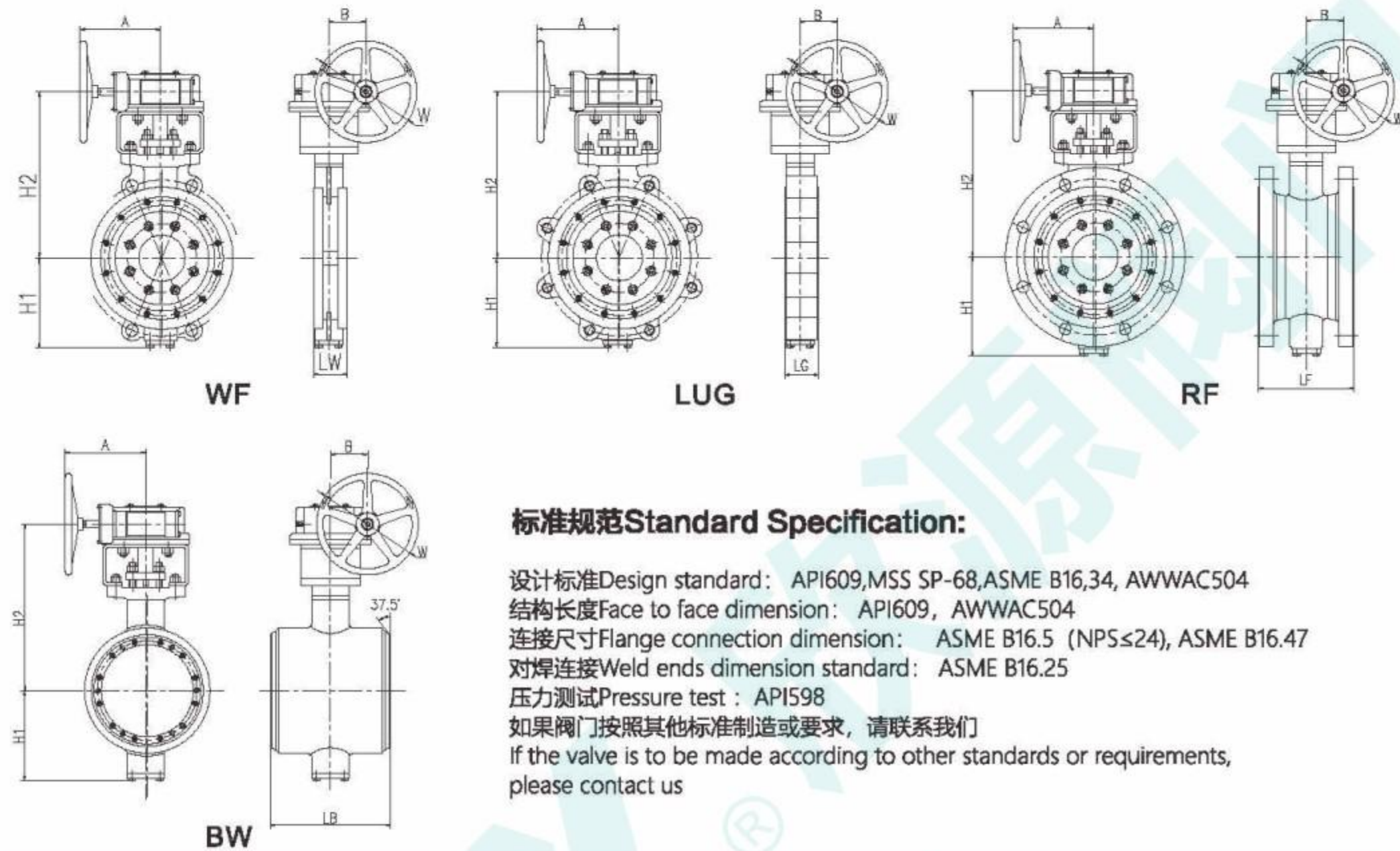

标准规范 Standard Specification:

设计标准 Design standard: API609, MSS SP-68, ASME B16.34, AWWAC504
 结构长度 Face to face dimension: API609, AWWAC504
 连接尺寸 Flange connection dimension: ASME B16.5 (NPS ≤ 24), ASME B16.47
 对焊连接 Weld ends dimension standard: ASME B16.25
 压力测试 Pressure test: API598
 如果阀门按照其他标准制造或要求, 请联系我们
 If the valve is to be made according to other standards or requirements, please contact us

Class 150									重量 weight (kg)			
NPS	LW/LG	LF	LB	H1	H2	A	B	W	WF	LUG	RF	BW
3	48	114	180	110	195	162	45	250	10	12	18	15
4	54	127	190	130	215	162	45	250	12	18	23	20
6	57	140	210	155	245	162	62	320	15	24	32	25
8	64	152	230	190	325	230	80	360	30	45	48	49
10	71	165	250	225	380	360	90	460	47	68	88	71
12	81	178	270	265	420	402	126	460	79	100	128	104
14	92	190	290	290	445	402	126	600	84	121	158	144
16	102	216	310	325	515	520	138	600	140	175	223	180
18	114	222	330	355	550	543	138	600	187	227	286	232
20	127	229	350	400	590	543	155	600	227	262	338	272
24	154	267	390	455	695	604	155	600	355	395	511	415
28	165	292	430	520	815	642	169	600	525	585	837	605
30	190	318	450	555	850	642	230	600	585	665	983	705
32	190	318	470	580	875	660	230	600	700	780	1163	720
36	203	330	510	650	990	855	254	600	1080	1050	1566	930
40	216	410	550	710	1050	855	254	600	1320	1570	2130	1670
48	254	470	630	820	1200	950	279	800	2050	2300	3260	2600
56	279	530	710	970	1765	1056	279	800	3100	3300	4700	3800
60	318	560	750	1020	1815	1056	308	800	3480	3600	5250	4230

多偏心金属密封蝶阀

Multi-eccentric metal seal butterfly valve

Class 300									重量 weight (kg)			
NPS	LW/LG	LF	LB	H1	H2	A	B	W	WF	LUG	RF	BW
3	48	114	180	120	210	162	45	250	14	16	20	17
4	54	127	190	145	245	162	62	320	20	23	30	25
6	59	140	210	180	320	230	80	360	42	45	58	50
8	73	152	230	210	370	402	90	460	60	66	82	71
10	83	165	250	245	445	520	126	460	110	120	146	130
12	92	178	270	290	780	520	126	600	136	148	186	160
14	117	190	290	325	525	543	138	600	194	212	262	228
16	133	216	310	365	585	604	155	600	264	286	350	308
18	149	222	330	395	640	604	155	600	280	328	412	358
20	159	229	350	425	735	642	169	600	415	450	555	485
24	181	267	390	505	305	660	230	600	544	598	760	652
28	229	292	430	580	920	855	230	600	845	925	1185	1015
30	241	318	450	620	950	855	254	600	1082	1184	1490	1286
32	241	318	470	650	1000	855	254	600	1190	1310	1670	1430
36	241	330	510	710	1080	130	279	800	1724	1878	2340	2030
40	300	410	550	730	1505	1056	279	800	2424	2628	3240	2832
48	350	470	630	830	1625	1056	308	800	2922	3210	4085	3496

Class 600									重量 weight (kg)			
NPS	LW/LG	LF	LB	H1	H2	A	B	W	WF	LUG	RF	BW
4	64	190	190	170	285	220	62	320	30	34	45	36
6	78	210	210	230	365	402	80	360	74	81	104	89
8	102	230	230	255	440	520	90	460	134	147	184	159
10	117	250	250	315	490	543	126	460	217	238	300	258
12	140	270	270	345	580	604	126	600	293	320	395	346
14	155	290	290	380	605	604	138	600	328	360	457	393
16	178	310	310	420	685	642	155	600	475	520	655	565
18	200	330	330	470	735	660	169	600	566	624	797	682
20	216	350	350	510	825	754	230	600	816	891	1114	965
24	232	390	390	565	880	855	230	600	1148	1262	1601	1375
28	270	430	430	630	1000	900	254	600	1772	1934	2420	2096
30	290	450	450	660	1470	1056	279	800	2304	2488	3040	2672
32	310	470	470	695	1510	1056	279	800	2468	2688	3314	2896
36	350	510	510	755	1570	1056	308	800	2820	3090	3900	3360

Class 900									重量 weight (kg)		
NPS	LW	LF	LB	H1	H2	A	B	W	WF	RF	BW
8	170	250	250	295	475	543	126	460	204	252	220
10	190	270	270	335	510	543	138	600	257	327	280
12	210	290	290	370	600	604	155	600	370	470	403
14	230	310	310	405	675	642	169	600	483	603	523
16	250	330	330	435	710	642	230	600	555	705	595
18	270	350	350	480	805	754	254	600	867	1080	938
20	290	370	370	515	825	855	279	800	1097	1365	1186
24	330	470	470	600	970	900	308	800	1950	2463	2120

多偏心金属密封蝶阀

Multi-eccentric metal seal butterfly valve

多偏心金属密封蝶阀

Multi-eccentric metal seal butterfly valve

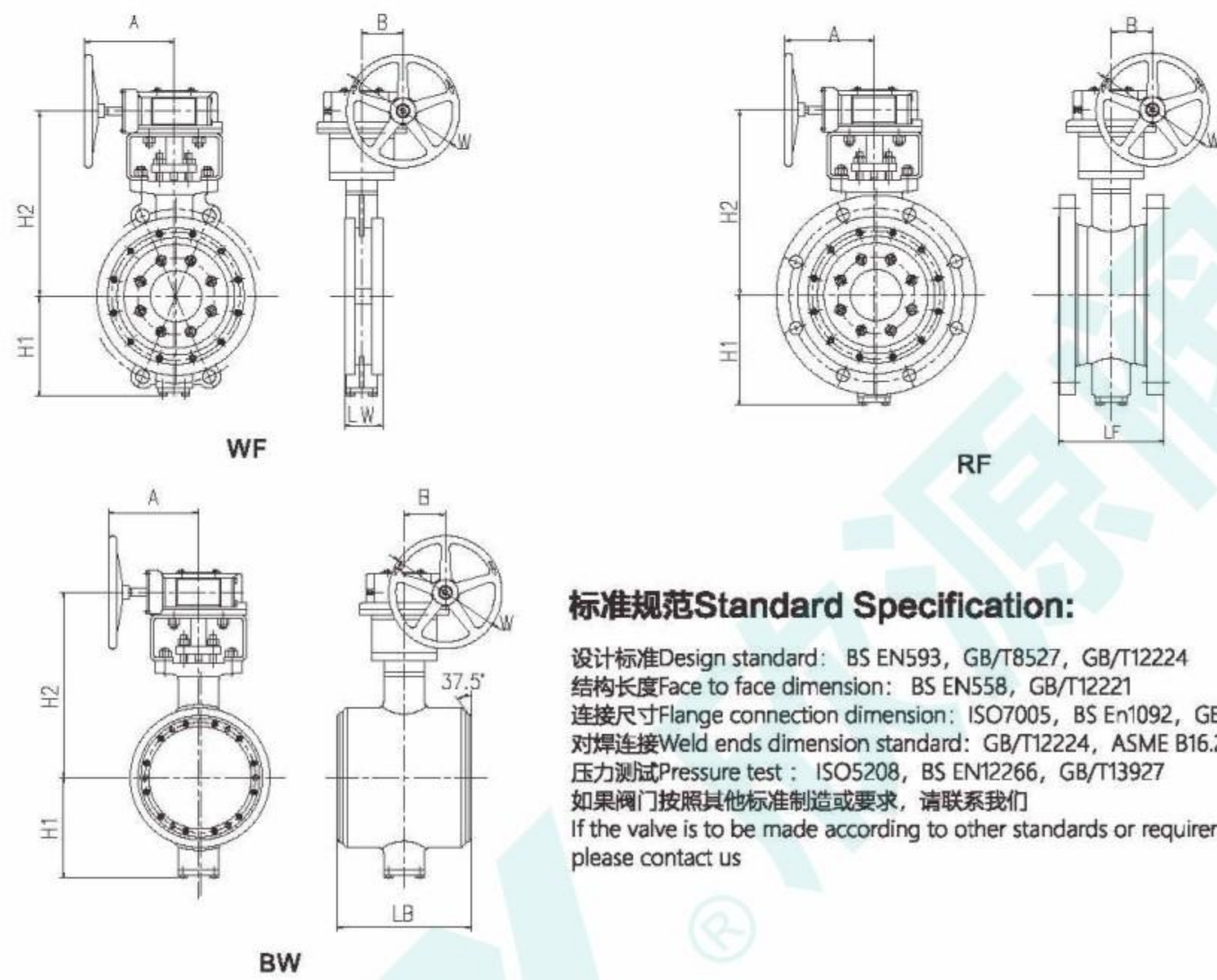

标准规范Standard Specification:

设计标准Design standard: BS EN593, GB/T8527, GB/T12224
 结构长度Face to face dimension: BS EN558, GB/T12221
 连接尺寸Flange connection dimension: ISO7005, BS EN1092, GB/T9113
 对焊连接Weld ends dimension standard: GB/T12224, ASME B16.25
 压力测试Pressure test: ISO5208, BS EN12266, GB/T13927
 如果阀门按照其他标准制造或要求, 请联系我们
 If the valve is to be made according to other standards or requirements, please contact us

PN6/10									重量 weight (kg)			
DN	LW	LF	LB	H1	H2	A	B	W	WF	RF(PN6)	RF(PN10)	BW
80	48	114	180	110	195	162	45	250	13	16	18	15
100	54	127	190	130	215	162	45	250	14	18	20	17
150	57	140	210	155	245	162	62	320	20	26	30	25
200	64	152	230	190	280	162	80	360	26	34	40	33
250	71	165	250	225	360	230	90	460	47	60	66	56
300	81	178	270	260	385	230	126	460	55	68	80	67
350	92	190	290	290	435	360	126	600	71	95	105	88
400	102	216	310	320	470	402	126	600	97	122	138	117
450	114	222	330	340	530	520	138	600	140	174	193	166
500	127	229	350	385	560	520	138	600	155	196	218	186
600	154	267	390	440	635	543	155	600	230	280	322	276
700	165	292	430	510	740	604	155	600	344	420	485	415
800	190	318	470	570	800	604	169	600	395	498	585	486
900	203	330	510	620	910	642	230	600	527	630	741	635
1000	216	410	550	675	1000	660	230	600	673	830	975	824
1200	254	470	630	800	1130	754	254	600	1127	1410	1655	1391
1400	279	530	710	910	1240	855	254	800	1712	2160	2540	2126
1600	318	600	790	1030	1435	901	279	800	2310	2850	3350	2830
1800	356	670	870	1130	1535	901	279	800	2960	3520	4400	3680
2000	406	760	950	1230	1635	901	308	800	3558	4638	5797	4478

PN16/25									重量 weight (kg)			
DN	LW	LF	LB	H1	H2	A	B	W	WF	RF(PN16)	RF(PN25)	BW
80	48	114	180	110	195	162	45	320	10	18	20	15
100	54	127	190	130	215	162	62	360	12	23	25	20
150	57	140	210	155	245	162	80	460	15	30	36	25
200	64	152	230	190	325	230	90	460	30	42	55	49
250	71	165	250	225	380	360	126	600	47	80	104	71
300	81	178	270	265	420	402	126	600	79	115	158	104
350	92	190	290	290	445	402	138	600	84	142	174	144
400	102	216	310	325	515	520	138	600	140	200	245	180
450	114	222	330	355	550	543	155	600	187	257	315	232
500	127	229	350	400	590	543	155	600	227	304	375	272
600	154	267	390	455	695	604	169	600	355	460	560	415
700	165	292	430	520	815	642	230	600	525	753	920	605
800	190	318	470	580	875	660	230	600	700	1045	1280	720
900	203	330	510	650	950	855	254	800	1080	1410	1723	930
1000	216	410	550	710	1010	855	254	800	1320	1920	2345	1670
1200	254	470	630	820	1090	950	279	800	2050	2935	3586	2600
1400	279	530	650	935	1180	1056	279	800	3100	4220	5170	3800
1600	318	600	680	1060	1275	1056	308	800	3680	5450	6560	4830
1800	356	670	720	1160	1375	1056	308	800	4580	6750	8252	6510
2000	406	760	760	1265	1485	1056	380	800	5860	8820	10780	7840

PN40/63									重量 weight (kg)			
DN	LW	LF	LB	H1	H2	A	B	W	WF	RF(PN40)	RF(PN63)	BW
80	64	180	180	120	210	162	62	360	14	17	23	17
100	64	190	190	145	245	162	80	460	20	25	35	25
150	76	210	210	180	320	230	90	460	42	51	65	50
200	89	230	230	210	370	402	126	600	60	68	88	71
250	114	250	250	245	445	520	126	600	110	124	156	130
300	114	270	270	290	780	520	138	600	136	156	205	160
350	127	290	290	325	525	543	155	600	194	218	302	228
400	140	310	310	365	585	604	169	600	264	308	396	308
450	152	330	330	395	640	604	169	800	280	332	462	358
500	152	350	350	425	735	642	230	800	415	485	625	485
600	178	390	390	505	305	660	230	800	544	652	868	652

PN100									重量 weight (kg)			
DN	LW	LF	LB	H1	H2	A	B	W	WF	RF	BW	
100	64	190	190	230	365	402	80	360	30	45	36	
150	76	210	210	255	440	520	90	460	74	104	89	
200	89	230	230	315	490	543	126	460	134	184	159	
250	114	250	250	345	580	604	126	600	217	300	258	
300	114	270	270	380	605	604	138	600	293	395	346	
350	127	290	290	420	685	642	155	600	328	457	393	
400	140	310	310	470	735	660	169	600	475	655	565	
450	152	330	330	510	825	754	230	600	566	797	682	
500	152	350	350	565	880	855	230	800	816	1114	965	
600	178	390	390	630	1000	900	254	800	1148	1601	1375	

多偏心金属密封蝶阀

Multi-eccentric metal seal butterfly valve

多偏心金属密封蝶阀

Multi-eccentric metal seal butterfly valve

SD600、MD700系列蝶阀工程数据

Sd600, MD700 series butterfly valve engineering data

蝶板开启角度Opening angle of butterfly plate
流量系数表Flow coefficient table

CLASS 150LB/PN16,25

口径DN in mm	10°	20°	30°	40°	50°	60°	70°	80°	90°
3 80	6	11	20	26	33	55	81	103	121
4 100	12	28	40	55	81	115	165	285	302
6 150	45	90	131	178	297	448	616	758	956
8 200	75	165	236	327	544	821	1130	1390	1621
10 250	124	268	445	566	820	1230	1860	2410	2700
12 300	248	544	810	989	1410	2120	3420	4600	5422
14 350	288	620	933	1250	1920	2890	3980	5690	6237
16 400	370	827	1254	1710	2520	3810	5410	7640	8220
18 450	480	1042	1571	2370	3145	4721	6980	9500	10600
20 500	552	1205	1844	2920	3626	5442	7960	10900	13000
24 600	838	1811	2730	4210	5500	8210	11921	16900	18800
28 700	1373	2997	4469	6100	8950	13510	19360	26910	29200
30 750	1643	3602	5355	7080	10710	16066	23300	31200	35700
32 800	1888	4098	6147	8160	12300	18450	26800	36300	41000
36 900	2467	5366	8040	10720	16000	24200	34300	47900	53000
40 1000	3031	6489	9885	13170	19860	29655	44000	56100	63900
42 1050	3308	7156	10784	14380	22400	32700	46500	63100	71021
48 1200	4450	9730	14595	19460	29800	43700	62900	87100	97300

CLASS 600LB/PN100

口径DN in mm	10°	20°	30°	40°	50°	60°	70°	80°	90°
3 80	6	9	15	20	28	45	61	99	110
4 100	12	23	40	44	66	99	144	199	223
6 150	25	72	110	134	202	307	437	608	672
8 200	48	108	160	211	316	475	685	940	1060
10 250	81	178	266	354	531	790	1148	1590	1770
12 300	132	286	430	573	860	1280	1880	2520	2900
14 350	188	400	614	810	1260	1850	2680	3660	4220
16 400	260	562	849	1133	1690	2590	3610	5020	5690
18 450	362	788	1180	1550	2550	3502	5200	7010	7830
20 500	461	1055	1587	2132	3080	4540	6530	9300	10100
24 600	695	1553	2330	3020	4510	6770	9856	13600	15800

注释Notes:

1) 定义Definition

CV: 温度为15°C时水流通过阀门且压降为1PSI时的流量 (加仑/分钟)

CV: flow rate (GPM) at 15 °C through valve and 1psi pressure drop

KV: 温度为15°C时水柱通过阀门且压降为1vbar时的流量 (m³/小时)

KV: flow rate when the water column passes through the valve and the pressure drop is 1vbar at 15 °C (m³ / h)

2) 流向为阀杆端向阀座方向

Flow direction is from stem end to valve seat

3) Cv=1.155Kv

CLASS 300LB/PN40,63

口径DN in mm	10°	20°	30°	40°	50°	60°	70°	80°	90°
3 80	6	12	17	25	33	50	72	99	110
4 100	12	26	40	53	76	113	164	223	252
6 150	25	72	110	162	268	347	500	689	725
8 200	65	148	222	298	492	730	998	1320	1330
10 250	110	228	357	540	891	1050	1548	2190	2410
12 300	163	356	530	807	1330	1620	2380	3220	3600
14 350	210	472	710	1020	1560	2150	3280	4560	4820
16 400	305	661	998	1330	1990	2990	4310	5920	6890
18 450	392	861	1200	1850	2550	3802	5500	7710	8630
20 500	476	1055	1587	2132	3380	4740	6930	9800	10100
24 600	776	1653	2530	3320	5310	7570	10856	15200	16800
28 700	1110	2430	3645	4861	7290	10835	15795	21873	24300
30 750	1423	3099	4655	6199	9300	13940	20140	27910	31000
32 800	1547	3360	5030	6630	10080	15110	21830	30240	33600
36 900	1962	4279	6431	8540	12840	19340	27820	38510	42800
40 1000	2421	5255	7893	10520	15780	23670	34190	47340	52600

标称CV值

Curva de Cv

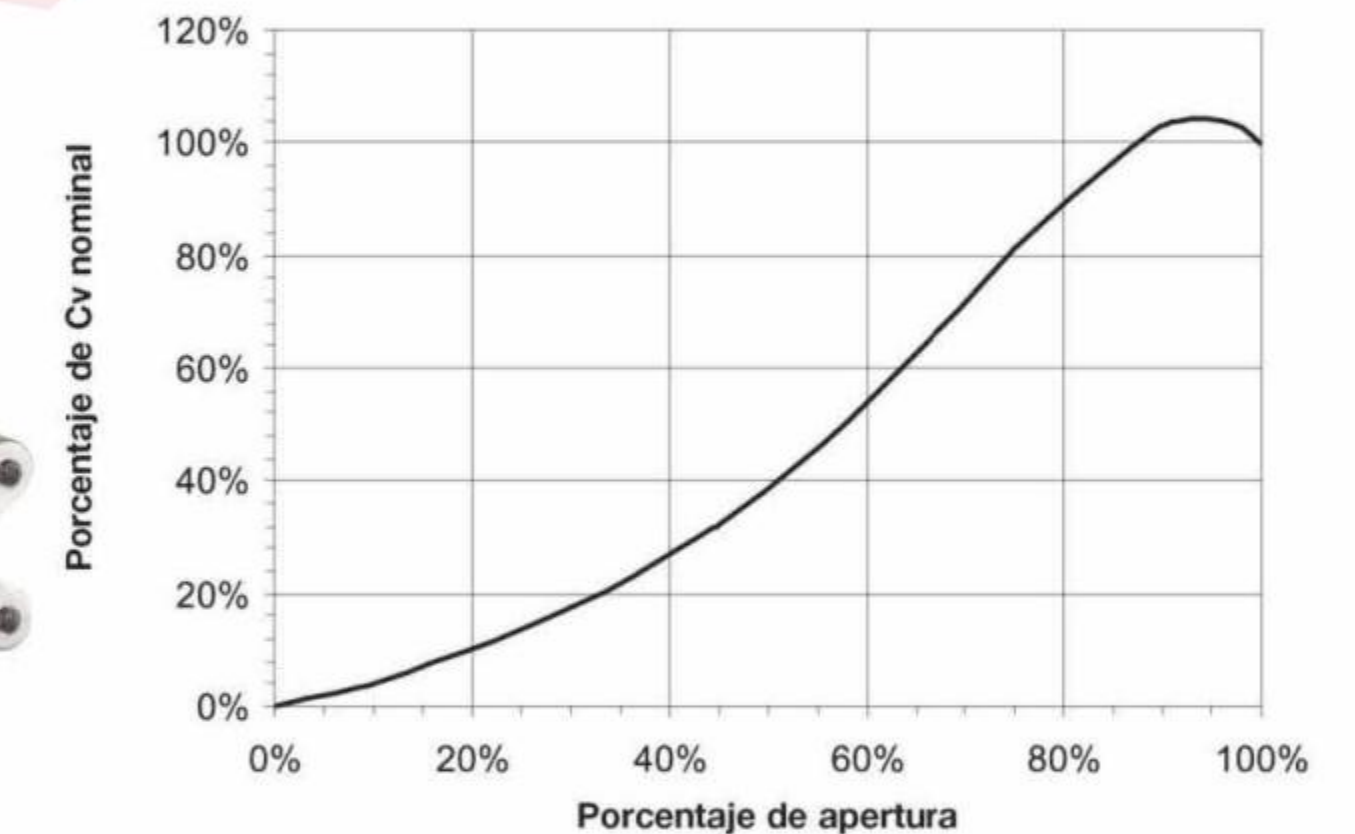

阀门开度



多偏心金属密封蝶阀

Multi-eccentric metal seal butterfly valve

多偏心金属密封蝶阀

Multi-eccentric metal seal butterfly valve

SD600、MD700系列蝶阀工程数据
SD600, MD700 series butterfly valve engineering data
阀门力矩表Valve torque table

Class 150LB

阀门口径 DN	运行扭矩 Torque		0.6Mpa				1.0Mpa				1.6Mpa				2.0Mpa			
			正向Forward		反向reverse		正向Forward		反向reverse		正向Forward		反向reverse		正向Forward		反向reverse	
			开启 Open	关闭 Close	开启 Open	关闭 Close	开启 Open	关闭 Close	开启 Open	关闭 Close	开启 Open	关闭 Close	开启 Open	关闭 Close	开启 Open	关闭 Close	开启 Open	关闭 Close
3"	80	35	75	75	75	78	75	75	75	78	75	75	75	98	75	75	75	98
4"	100	43	98	98	98	118	98	98	98	118	108	98	108	147	108	98	108	147
6"	150	61	123	127	123	206	123	127	123	206	161	127	161	257	186	127	186	290
8"	200	83	201	235	201	313	201	235	201	375	284	235	284	470	323	235	323	534
10"	250	139	333	363	333	503	333	363	333	607	452	363	452	761	530	363	530	864
12"	300	167	462	539	462	740	462	539	462	899	641	539	641	1136	760	539	760	1295
14"	350	218	590	701	590	915	590	701	590	1112	815	701	815	1408	966	701	966	1605
16"	400	340	857	1029	857	1277	857	1029	857	1547	1170	1029	1170	1953	1380	1029	1380	2225
18"	450	504	1001	1205	1001	1819	1338	1205	1338	2237	1844	1205	1844	2864	2182	1205	2182	3282
20"	500	815	1526	1750	1526	2634	2011	1750	2011	3227	2738	1750	2738	4117	3223	1752	3223	4711
24"	600	1138	2275	2532	2275	3936	3049	2532	3049	4872	4209	2532	4209	6275	4982	2532	4982	7211
28"	700	1942	3712	4403	3712	6076	4919	4403	4919	7513	6728	4403	6728	9669	7934	4403	7934	11105
30"	750	2192	4270	5698	4270	7417	5685	5698	5685	9139	7807	5698	7807	11721	9222	5796	9222	13443
32"	800	3265	5826	7130	5826	9686	7576	7130	7576	11813	10202	7130	10202	15004	11952	7130	11952	17130
36"	900	3638	6534	9623	6534	11237	8511	9623	8511	13674	11479	9623	11479	17330	13457	9623	13457	19767
38"	950	4032	7649	11601	7649	13350	10114	11601	10114	16371	13811	11601	13811	20902	16276	11599	16276	23924
40"	1000	4445	8457	12962	8457	14625	11191	12962	11191	17959	15292	12962	15292	22963	18025	12962	18025	26298
42"	1050	4878	9397	14610	9397	16179	12475	14610	12475	19918	17092	14610	17092	25527	20170	14610	20170	29266
44"	1100	5805	11866	16321	11866	19791	15984	16321	15984	24682	22161	16321	22161	32019	26279	16321	26279	36910
48"	1200	6813	14998	19257	14998	23848	20546	19257	20546	30258	28866	19257	28866	39874	34414	19257	34414	46285

Class 300LB

阀门口径 DN	运行扭矩 Torque		1.6Mpa				2.5Mpa				4.0Mpa				5.1Mpa			
			正向Forward		反向reverse		正向Forward		反向reverse		正向Forward		反向reverse		正向Forward		反向reverse	
			开启 Open	关闭 Close	开启 Open	关闭 Close	开启 Open	关闭 Close	开启 Open	关闭 Close	开启 Open	关闭 Close	开启 Open	关闭 Close	开启 Open	关闭 Close	开启 Open	关闭 Close
3"	80	42	87	79	87	106	91	79	91	119	124	79	124	163	148	79	148	191
4"	100	52	124	103	124	168	135	103	135	192	190	103	190	260	230	103	230	310
6"	150	100	256	155	256	366	300	155	300	418	427	155	427	577	522	155	522	693
8"	200	167	464	286	464	689	543	286	543	789	783	286	783	1091	959	286	959	1311
10"	250	262	764	449	764	1120	899	449	899	1285	1304	449	1304	1787	1602	449	1602	2155
12"	300	408	1045	980	1045	1610	1217	980	1217	1833	1738	980	1738	2508	2120	980	2120	3003
14"	350	978	2068	1272	2068	2750	2373	1272	2373	3116	3294	1272	3294	4222	3973	1272	3973	5033
16"	400	1163	2632	1497	2632	3616	3036	1497	3036	4109	4259	1497	4259	5599	5155	1497	5155	6693
18"	450	1366	3278	1954	3278	4507	3800	1954	3800	5139	5377	1954	5377	7153	6533	1954	6533	8453
20"	500	1706	4539	3134	4539	6069	5227	3134	5227	6894	7310	3134	7310	9394	8837	3134	8837	11226
24"	600	2627	6155	5478	6155	8794	7118	5478	7118	9995	10036	5478	10036	13633	12176	5478	12176	16300
28"	700	3890	9786	8353	9786	13548	11378	8353	11378	15478	16202	8353	16202	21325	19739	8353	19739	25614
30"	750	4860	13035	11561	13035	19077	15223	11561	15223	21808	21855	11561	21855	30085	26717	11561	26717	36155
32"	800	5358	13454	14202	13454	18856	15641	14202	15641	21529	22266	14202	22266	29625	27124	14202	27124	35563
36"	900	7000	17794	19218	17794	24505	20705	19218	20705	28019	29523	19218	29523	38665	35989	19218	35989	46473
40"	1000	8214	24765	22698	24765	33628	29140	22698	29140	38799	42394	22698	42394	54467	52113	22698	52113	65957

Class 600LB

阀门口径 DN	运行扭矩 Torque		2.5Mpa				5.0Mpa				7.5Mpa				10.2Mpa			
			正向Forward		反向reverse		正向Forward		反向reverse		正向Forward		反向reverse		正向Forward		反向reverse	
			开启 Open	关闭 Close	开启 Open	关闭 Close	开启 Open	关闭 Close	开启 Open	关闭 Close	开启 Open	关闭 Close	开启 Open	关闭 Close	开启 Open	关闭 Close	开启 Open	关闭 Close
3"	80	92	120	105	120	161	161	105	161	218	201	105	201	275	244	105	244	337
4"	100	125	186	151	186	257	263	151	263	364	339	151	339	470	422	151	422	586
6"	150	327	487	554	487	677	689	554	689	958	890	554	890	1239	1109	554	1109	1542
8"	200	510	872	683	872	1189	1298	683	1298	1748	1725	683	1725	2307	2185	683	2185	2911
10"	250	1223	1779	1777	1779	2325	2490	1777	2490	3262	3200	1777	3200	4200	3967	1777	3967	5212
12"	300	1707	2300	2533	2300	3090	3405	2533	3405	4524	4510	2533	4510	5960	5704	2533	5704	7509
14"	350	1978	3122	3557	3122	4088	4513	3557	4513	5881	6114	3557	6114	7673	7406	3557	7406	9611
16"	400	2912	4794	4389	4794	6046	7040	4389	7040	8814	9286	4389	9286	11582	11712	4389	11712	14571
18"	450	4893	7623	5977	7623	9218	10965	5977	10965	13225	14306	5977	14306	17232	17915	5977	17915	21559
20"	500	6040	9575	8122	9575	11513	13864	8122	13864	16610	18152	8122	18152	21708	22785	8122	22785	27212
24"	600	6700	14427	14828	14427	17588	21243	14828	21243	25720	28058	14828	28058	33852	35419	14828	35419	42635

注意事项Matters needing attention

- 一, 表中扭矩值为室温下的设计计算值。在选择执行机构时, 应考虑一定的安全系数。一般工况下, SD600系列多层次密封蝶阀乘1.3到1.5倍, MD700系列全金属密封蝶阀乘1.5到18倍。
- 1. The torque value in the table is the design calculated value at room temperature. A certain safety factor should be considered when selecting the actuator. Under general working conditions, the torque of SD600 series multi-layer sealed car is multiplied by 1.3 to 1.5 times, and the torque of MD700 series all-metal sealed car is multiplied by 1.5 to 18 times.
- 二, 当实际压力小于表中数值时, 按公称压力值选择。
- 2. When the actual pressure is less than the value in the table, it shall be selected according to the nominal pressure value.
- 三, 此表仅供参考。选择执行机构时请与我公司确认。我们保留不通知客户修改数据的权利。
- 3. This form is for reference only. Please confirm with our company when choosing the executing agency. We reserve the right not to inform customers to modify the data.

高性能蝶阀

High performance butterfly valve

高性能蝶阀

High performance butterfly valve



一般应用

- 调节功能
- 机场燃料补给
- 烃类工艺
- 化工/石化工艺
- 气体净化
- 蒸汽及真空
- 电厂及公用
- 工程制冷
- 供热通风与空气调节HVAC
- 氧化铝精炼

Application

- Regulating function
- Airport refuelling
- Hydrocarbon process
- Chemical/petrochemical process
- Gas purification
- Steam and vacuum
- Power plants and utilities
- Refrigeration engineering
- Heating ventilation and air conditioning HVAC
- Alumina refining

产品特点

- 符合最新版本的API609标准要求，结合先进的设计理念和智能制造技术，采用可更换的弹性阀座，具有以下特点：
- *双偏心结构设计，达到开启即分离，关闭即密封的效果。
- *独特设计的唇型密封结构，在弹性过盈和自密封作用下达到双向气泡级零泄漏。
- *可互换的聚合物和橡胶阀座可适用于各种不同工况环境下使用，达到最佳的使用寿命和效果。
- *所有阀门均标配防吹出阀杆设计，确保在工况使用的安全可靠。
- *填料的设计使产品可应用低泄漏和真空工况下使用，而无需进行调整和特殊处理。
- *阀杆的切向销一半在阀板上，一半在阀杆内，切向定位使阀板和阀承受的挤压力而非剪切应力，使连接更加可靠。
- *阀体内的阀杆轴颈端和阀板设计成最小距离，以提供阀杆最大的支撑增强阀杆受力，降低开关力矩和轴承磨损
- *阀板限位块和阀体铸成一体，使阀板相对阀座定位精准，延长阀座的使用寿命。
- *整体铸造的ISO 5211标准上法兰和方形连接轴，可方便可靠连接任何形式的驱动装置

Product characteristics

According to the latest version of the API609 standard requirements, combined with advanced design concepts and intelligent manufacturing technology, the use of replaceable elastic seat, with the following characteristics:

- * Double eccentric structure designed to achieve the effect of opening and separating, closing and sealing.
- * Uniquely designed lip seal structure with zero leakage at two-way bubble level for elastic interference and self-sealing.
- * Interchangeable polymer and rubber seats are suitable for use under various operating conditions for optimal service life and effectiveness.
- * All valves are standard with blow-out stem design to ensure safety and reliability in operating conditions.
- * The packing is designed so that the product can be used under low leakage and vacuum conditions without adjustment and special treatment.
- * The tangential pin of the valve stem is half on the valve plate and half inside the valve stem. The tangential positioning makes the valve plate and valve under extrusion pressure rather than shear stress, making the connection more reliable.
- :: Stem journal ends and valve plates in the valve body are designed to provide maximum stem support to enhance stem force and reduce switching torque and bearing wear.
- Valve plate closing limit block and valve body cast into one, so that the valve plate relative to the seat positioning accuracy, extend the service life of the seat.
- * ISO 5211 standard upper flange and square connecting shaft for integral casting for easy and reliable connection to any form of drive

阀座密封性 Seat sealing all

所有聚合物阀座的阀门均在工厂经过严格压力试验，按标准1.1倍额定压力工况下的双向切断严密性测试，泄漏量达到无气泡级零泄漏，高于 ANSI/FCI 70-2 的标准规定 VI 级泄漏要求。

ANSI/FCI 70-2 此标准确定了控制阀阀座泄漏量的六个等级，标准的泄漏等级、泄漏量和测试条件如下：

polymer seat valves in the factory after strict pressure test, according to the standard 1.1 times rated pressure under the two-way cut-off tightness test, leakage up to bubble-free zero leakage, higher than the ANSI/FCI 70-2 standard level VI leakage requirements.

ANSI/FCI 70-2 this standard, six levels of control valve seat leakage are determined. The standard leakage levels, leakage levels and test conditions are as follows:

ANSI/FCI 70-2-2013

最大泄漏量 Maximum leakage

VI级	公称口径DN(气泡数量Bubble number)	毫升/分钟ML/min	试验介质 空气或氮气	试验和温度 工作压力或3.4bar压差，以最低者为准 温度10到52°C。
	50(2)	3		
	65(2.5)	4		
	80(3)	6		
	100(4)	11		
	150(6)	27		
	200(8)	45		
	250(10)	11.1		
	300(12)	16.0		
	350(14)	21.6		
	400(16)	28.4		
V级	[5X10-12m3/秒/bar压差/mm通道直径]		水	工作压力，温度10到52°C
IV级	[5 X10-12m3/ s/ bar pressure difference/ mm channel diameter]		空气或水	工作压力或3.4bar压差，以最低者为准，温度10到52°C。
	0.01% of rated flow capacity when valve is fully open		water Air or water	operating pressure differential, temperature °C 10 to 52 Working pressure or 3.4 bar pressure difference, whichever is lowest, temperature °C 10 to 52

不同阀座材料的温压曲线 Temperature and pressure curves for different seat materials

橡胶阀座

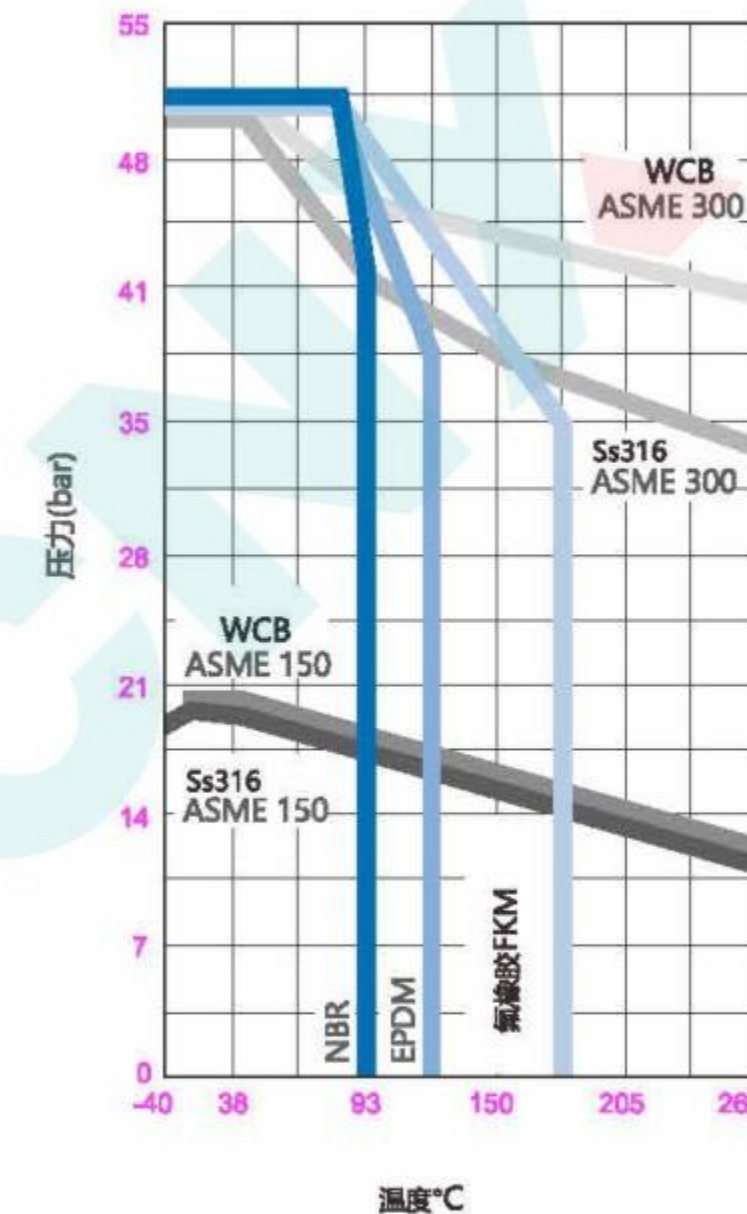

聚合物阀座

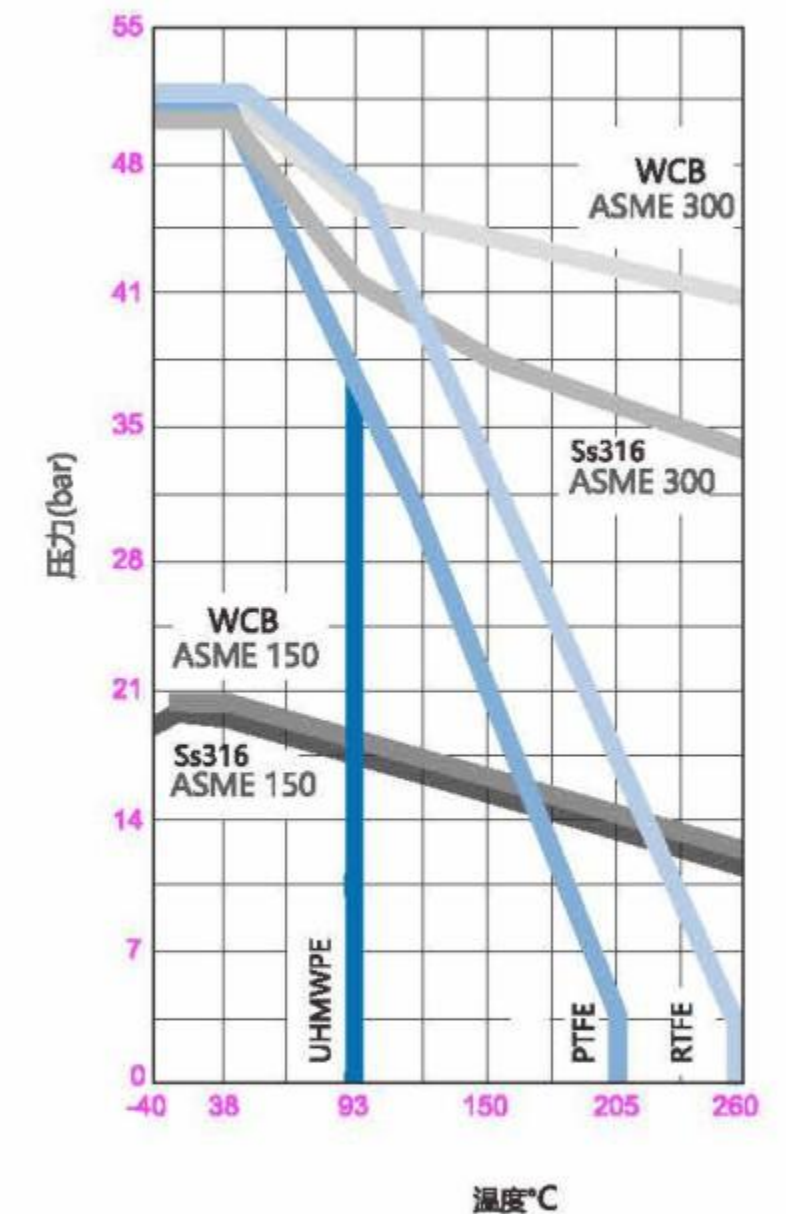

高性能蝶阀

High performance butterfly valve

结构设计

采用双偏心结构，阀杆轴孔和阀体中心偏移A；阀座和阀体中心偏移B，在2个偏心作用下蝶板关闭时，由旋转到平移，使之与阀座吻合，蝶板开启时，由于偏心的作用使蝶板与阀座密封面迅速完全分离从而大大减轻了密封面磨损和启闭扭矩。

密封面采用球弧面设计，光洁度达到镜面，当介质压力越大蝶板受压越大，其密封性能越好。阀座密封材料采用聚四氟乙烯或增强聚四氟乙烯，它与蝶板球弧面的摩擦系数仅有0.07甚至更小，同时还解决了耐温、耐磨、耐老化的难题，并提高工作压力，延长了使用寿命，扩大使用范围。

Structural design

With double eccentric structure, stem shaft hole and body center offset A; seat and body center offset B, at 2 eccentricity. When the lower butterfly plate is closed, it is rotated to the translation to match the seat. When the butterfly plate is opened, the butterfly plate and the seat the seat sealing surface quickly and completely because of the eccentricity, which greatly reduces the wear of the sealing surface and the opening and closing torque.

The sealing surface is designed with spherical arc surface, and the finish reaches the mirror surface. When the medium pressure is greater, the butterfly plate is more compressed, and the sealing performance is better. The seat sealing material is made of PTFE or reinforced PTFE. The friction coefficient between the seat sealing material and the spherical arc surface of the butterfly plate is only 0.07 or less. At the same time, it solves the problems of temperature resistance, wear resistance and aging resistance, and improves the working pressure, prolongs the service life and expands the scope of use.

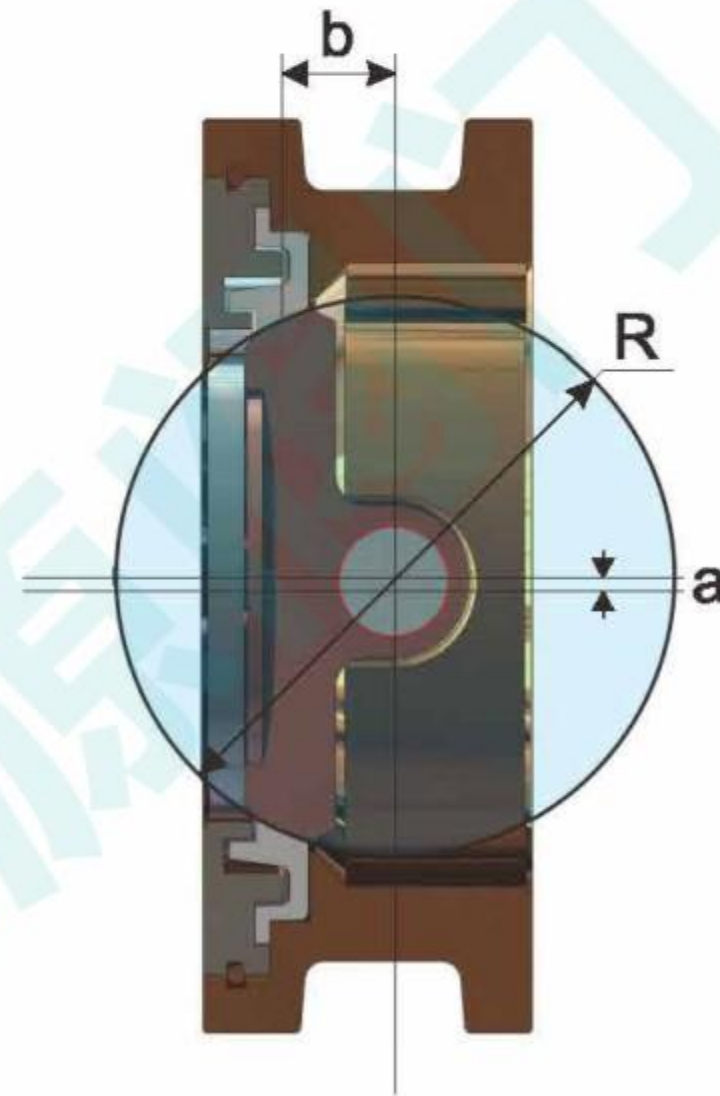

轴向密封

*符合推行的防逸散泄漏标准的要求加强了对轴向微泄漏的控制，轴向填料采用V形低泄漏填料和动载弹簧垫圈加载，保证了填料的密封可靠性。

*可提供带隔环的双重填料密封和检测孔，该填料采用上下双道密封，通过检测口可以对头道密封进行检测，用在填料密封要求苛刻工况下

*在真空系统工况下，填料设计采用正装和反装的双V型填料结构，这种结构能保证管道介质不会外泄漏又能保证外界空气不能进入管道系统。

Axial seal

*Control of axial microleakage is strengthened in compliance with the requirements of the implemented anti-leakage standards. The axial packing is loaded with V low-leakage packing and dynamic spring pad to ensure the sealing reliability of the packing.

*Double packing seals and test holes with spacer rings are provided. The packing is made up of upper and lower double-channel seals, which can be tested through the test ports for use under harsh packing conditions

* Under vacuum system conditions, the packing design adopts double V packing structure with formal and reverse loading, which ensures that the pipeline medium will not leak out and that the external air will not enter the pipeline system.

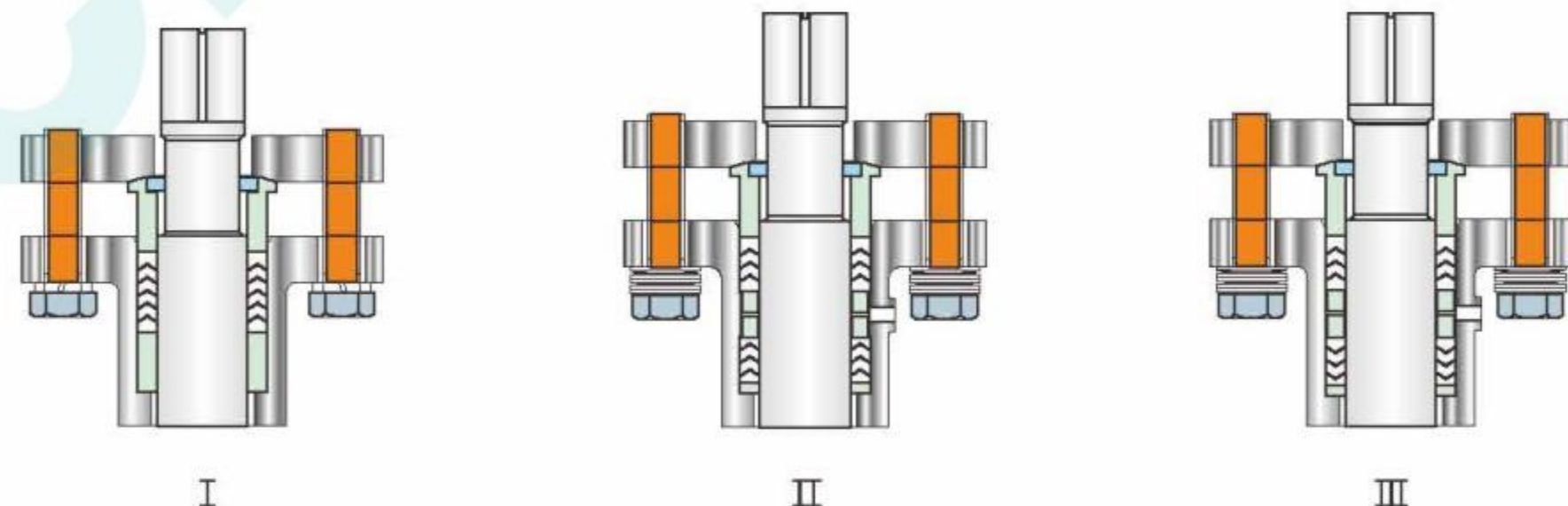

密封副

阀座具有特殊的截面形状使其弹性更好，并与阀板密封面过盈配合达到最佳密封效果，同时借助管路中的介质辅助力使阀座始终紧密贴合在蝶板密封面上，使密封性能得到长期保证，当阀门开启或压力卸载后，密封圈又恢复原来初始状态，使密封圈在工况下长期使用不磨损、不变形、使用寿命更长。

这种设计的阀座密封副可实现蝶阀的双向气泡级密封，当介质正向流动时，介质压力作用在进口侧的蝶板面上，使蝶板产生轴向位移向阀座靠近，保证了阀门正向密封(见图)；当介质反向流动时，介质压力作用在阀座一侧的表面上，介质压力使密封副产生反向变形，压向蝶板密封面形成密封比压阻止介质泄漏，保证了阀门反向密封(见图)。

Sealing pair

The seat has a special cross-section shape to make it more elastic, and the valve plate sealing cover interference fit to achieve the best sealing

At the same time, with the help of the medium auxiliary force in the pipeline, the seat is always tightly attached to the butterfly plate sealing surface, so that the sealing performance is guaranteed for a long time. When the valve is opened or pressure unloaded, the sealing ring returns to its original initial state. The designed seat seal ring can realize the bidirectional bubble seal of butterfly valve. When the medium flows forward, the medium pressure acts on the butterfly plate surface on the inlet side, which makes the butterfly plate produce axial displacement close to the valve seat. Medium pressure causes reverse deformation of sealing ring, pressure to butterfly seal surface to prevent leakage and valve reverse seal (see figure).

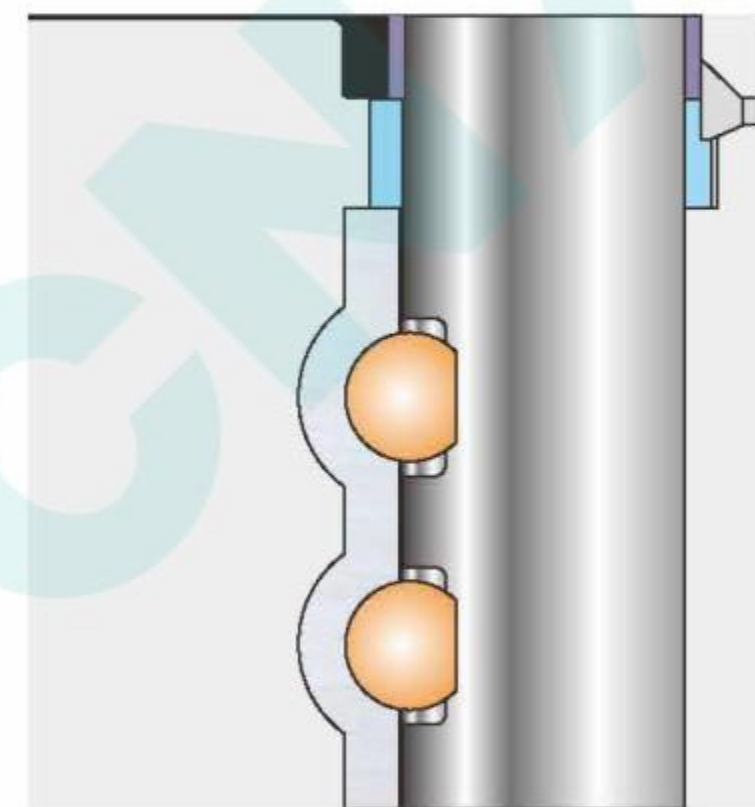
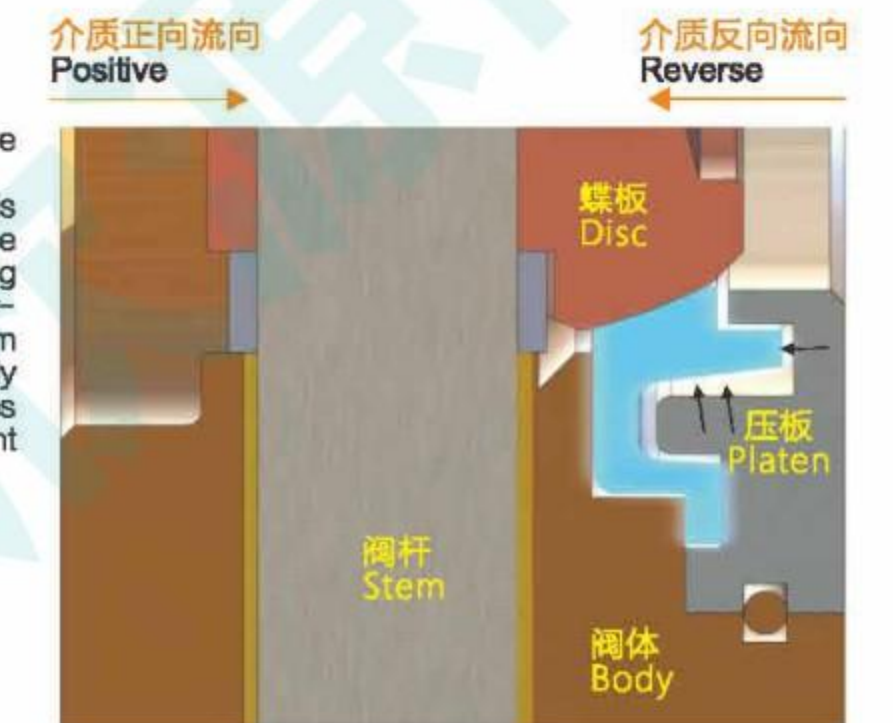
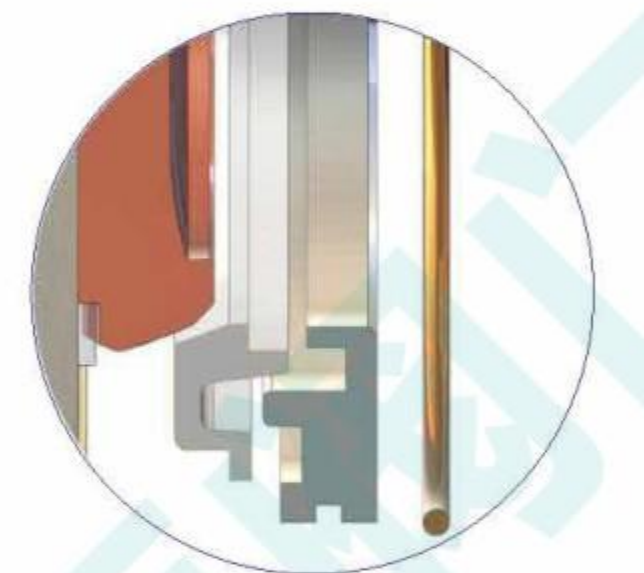

轴向定位和连接

蝶板上下有定位套，将蝶板固定在阀体中心旋转，这种设计能长期保持蝶板密封和阀座的对中性，提高阀门的密封寿命。

阀杆上均标配有防吹出挡环设计，符合API609标准要求，确保在工况使用的安全可靠。

阀杆采用切向销连接，一半在阀板上，一半在阀杆内，切向定位使阀板和阀承受的压力而非剪切应力，使连接更加可靠。

Axial positioning and connection

The butterfly plate has a positioning sleeve up and down, and the butterfly plate is fixed in the center of the valve body to rotate. This design can keep the butterfly plate seal and seat neutral for a long time, and improve the sealing life of the valve. All stem are equipped with anti-blowing ring design, meet the requirements of API609 standards, to ensure the safety and reliability of use in working conditions. The stem is connected by tangential pin, half on the valve plate and half in the stem. The tangential positioning makes the valve plate and valve bear extrusion pressure rather than shear stress, which makes the connection more reliable.

高性能蝶阀

High performance butterfly valve

产品分解图

Product Decomposition

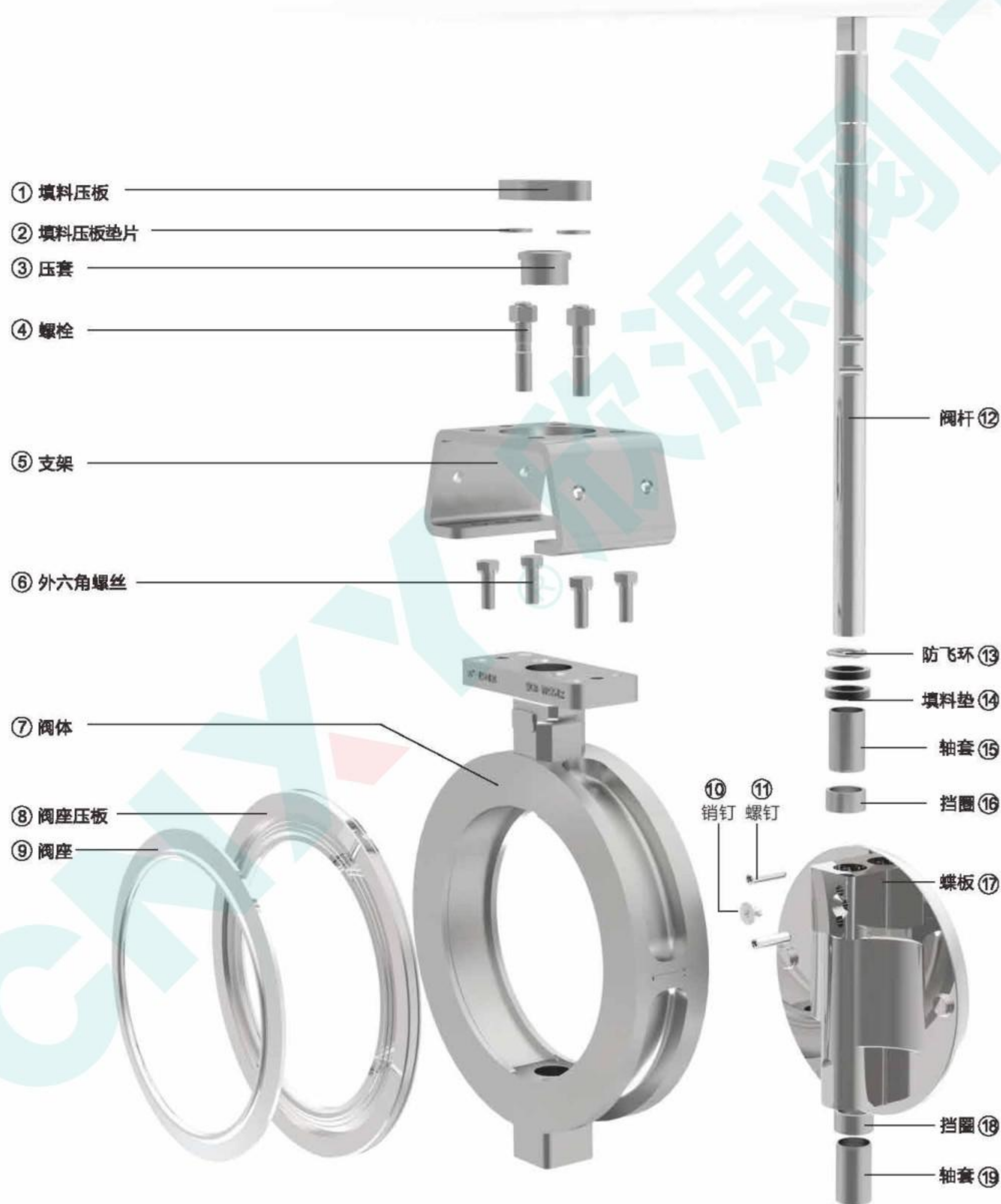

高性能蝶阀

High performance butterfly valve

Technical data

Valve body type: clamp, lug and double flange
 Size range :DN50 to DN1200(NPS2 to 48)
 Pressure rating: Class150-300,PN16-40
 Vacuum :1.016 × 10⁻³ mm(4x105in)Hg
 Temperature range :-40 □ to -250□
 Main materials: WCB, LCB, CF8, CF3, CF8M, CF3M, 4A, 6A, titanium alloy, copper alloy, etc
 Lug and double flanged valve bodies are designed for full rated pressure bidirectional sealing pipe end installation applications.

技术数据

阀体类型:对夹、支耳及双法兰
 尺寸范围:DN50至DN1200(NPS2至48)
 压力等级:CLASS150-300,PN16-40
 真空度:1.016×10⁻³ mm(4x105in)Hg
 温度范围:-40至-250℃
 主体材料: WCB、LCB、CF8、CF3、CF8M、CF3M、4A、6A、钛合金、铜合金等
 支耳式和双法兰式阀体适用于全额定压力双向密封管道末端安装应用。

产品零件清单 Product Parts List

No.	部件名称 Spare Part Name	材料组别Material Group			
		WCB	LCB	CF8	CF8M
1	填料压板 Packing pressure plate	SS304	SS304	SS304	SS304
2	填料压板垫片 Packing pressure plate gasket	SS304	SS304	SS304	SS304
3	压套 Pressure sleeve	SS304	SS304	SS304	SS316
4	螺栓 Bolt	A2-70	A2-70	A2-70	A4-70
5	支架 Bracket	SS304	SS304	SS304	SS304
6	外六角螺丝 Hexagon socket screw	A2-70	A2-70	A2-70	A4-70
7	阀体 Valve body	WCB	WCB	CF8	CF8M
8	阀座压板 Valve seat pressure plate	A105	SS304	SS304	SS316
9	阀座 Valve seat	PTFE/PTFE	PTFE/PTFE	PTFE/PTFE	PTFE/PTFE
10	销钉 Pin	SS304	SS304	SS304	SS316
11	螺钉 Screw	SS304	SS304	SS304	SS316
12	阀杆 Valve stem	SS410	SS410	17-4PH	17-4PH
13	防飞环 Anti-flying ring	SS304	SS304	SS304	SS304
14	填料垫 Packing pad	PTFE	PTFE	PTFE	PTFE
15	轴套 Shaft sleeve	SF-1	SF-1S	SF-1S	SF-1SS
16	挡圈 Retaining ring	SS304	SS304	SS304	SS316
17	蝶板 Butterfly plate	CF8M	CF8M	CF8M	CF8M
18	挡圈 Retaining ring	SS304	SS304	SS304	SS316
19	轴套 Shaft sleeve	SF-1	SF-1S	SF-1S	SF-1SS

***需要特殊的阀体和内部零件材料: 如双相不锈钢, 蒙乃尔合金, 哈氏合金, 铜合金等特殊材料, 请联系我们的销售工程师
 Special valve body and internal parts materials are needed: such as duplex stainless steel, Monel alloy, Hastelloy, copper alloy and other special materials, please contact our Sales Engineer

高性能蝶阀

High performance butterfly valve

高性能蝶阀

High performance butterfly valve

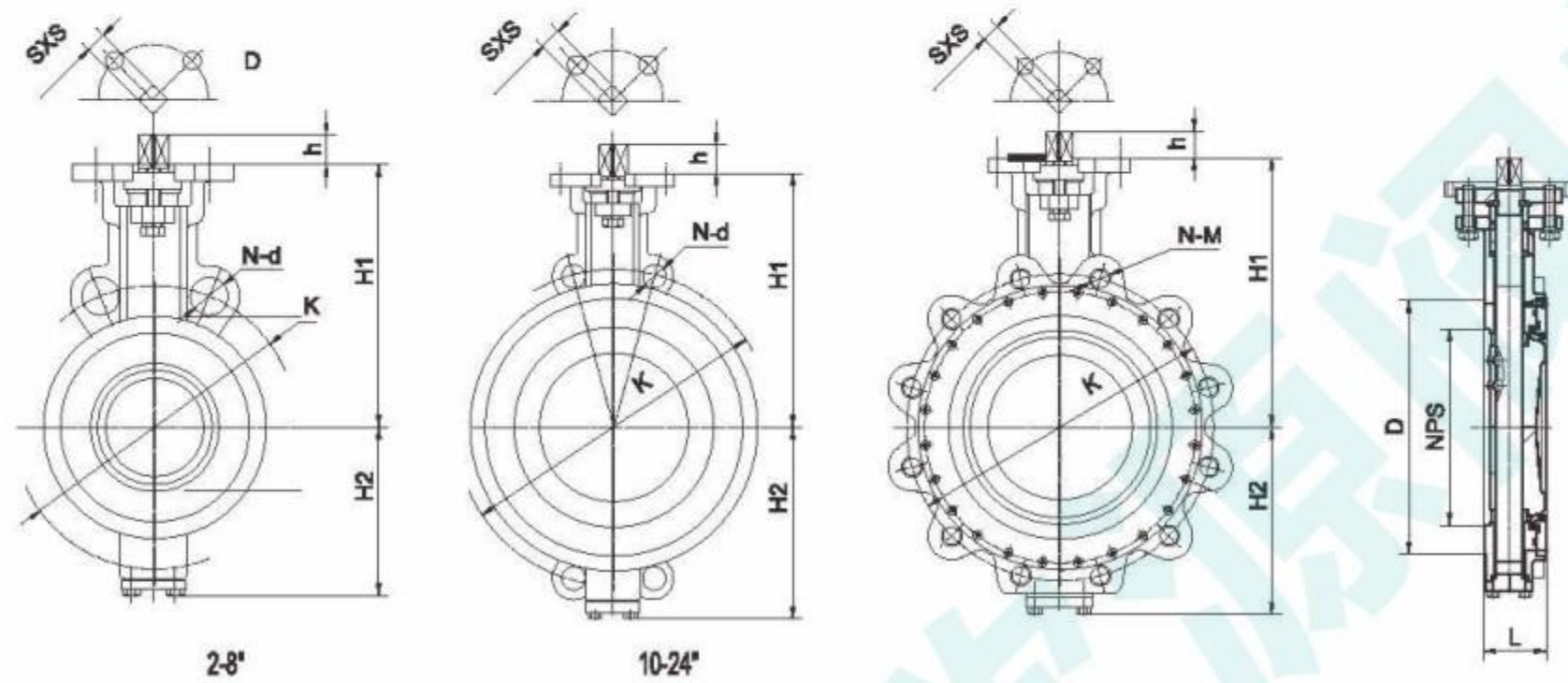

Class 150												重量 (kg)	
NPS	DN	L	K	D	H1	H2	N-d	N-M	ISO5211	SXS	h	WF	LUG
2	50	44	120.5	92	125	66	4-19	4-5/8	F05	11X11	16	5	6
2.5	65	46	139.5	105	138	78	4-19	4-5/8	F05	11X11	16	6	7
3	80	48	152.5	127	156	100	4-19	4-5/8	F07	14X14	18	7	9
4	100	54	190.5	157	168	115	8-19	8-5/8	F07	14X14	22	8	10
5	125	56	216	186	188	135	8-22	8-3/4	F10	17X17	22	11	14
6	150	57	241.5	216	205	150	8-22	8-3/4	F10	17X17	22	15	18
8	200	64	298.5	270	240	182	8-22	8-3/4	F12	22X22	27	22	28
10	250	71	362	324	280	216	12-25	12-7/8	F12	22X22	27	34	40
12	300	81	432	381	322	256	12-25	12-7/8	F14	27X27	32	53	68
14	350	92	476	413	375	285	12-29	12-1	F14	27X27	32	60	85
16	400	102	540	470	400	325	16-29	16-1	F14	36X36	42	82	95
18	450	114	578	533	480	350	16-32	16-1/8	F16	36X36	42	130	156
20	500	127	635	584	512	402	20-32	20-1/8	F16	46X46	54	170	210
24	600	154	749.5	692	570	455	20-35	20-1/4	F16	46X46	54	265	320

Class 300												重量 (kg)	
NPS	DN	L	K	D	H1	H2	N-d	N-M	ISO5211	SXS	h	WF	LUG
2	50	44	127	92	125	66	8-19	8-5/8	F05	11X11	16	5	6
2.5	65	46	149	105	138	78	8-22	8-3/4	F05	11X11	16	6	7
3	80	48	168.5	127	156	100	8-22	8-3/4	F07	14X14	18	7	9
4	100	54	200	157	168	115	8-22	8-3/4	F07	14X14	22	8	10
5	125	56	235	186	188	135	8-22	8-3/4	F10	17X17	22	11	14
6	150	59	270	216	215	155	12-22	12-3/4	F12	22X22	22	17	20
8	200	73	330	270	255	195	12-25	12-7/8	F12	22X22	27	26	36
10	250	83	387.5	324	298	232	16-29	16-1	F14	27X27	27	42	54
12	300	92	451	381	342	278	16-32	16-1/8	F14	27X27	32	58	82
14	350	117	514.5	413	398	305	20-32	20-1/8	F16	36X36	32	95	132
16	400	133	571.5	470	430	355	20-35	20-1/4	F16	36X36	42	124	175

PN16												重量 (kg)	
NPS	DN	L	K	D	H1	H2	N-d	N-M	ISO5211	SXS	h	WF	LUG
2	50	44	125	99	125	66	4-18	4-M16	F05	11X11	16	5	6
2.5	65	46	145	118	138	78	4-18	4-M16	F05	11X11	16	6	7
3	80	48	160	132	156	100	8-18	8-M16	F07	14X14	18	7	9
4	100	54	180	156	168	115	8-18	8-M16	F07	14X14	22	8	10
5	125	56	210	184	188	135	8-18	8-M16	F10	17X17	22	11	14
6	150	57	240	211	205	150	8-22	8-M20	F10	17X17	22	15	18
8	200	64	295	266	240	182	12-22	12-M20	F12	22X22	27	22	28
10	250	71	355	319	280	216	12-26	12-M24	F12	22X22	27	34	40
12	300	81	410	370	322	256	12-26	12-M24	F14	27X27	32	53	68
14	350	92	470	429	375	285	16-26	16-M24	F14	27X27	32	60	85
16	400	102	525	480	400	325	16-30	16-M27	F14	36X36	42	82	95
18	450	114	585	548	480	350	20-30	20-M27	F16	36X36	42	130	156
20	500	127	650	609	512	402	20-33	20-M30	F16	46X46	54	170	210
24	600	154	770	720	570	455	20-36	20-M33	F16	46X46	54	265	320

PN25												重量 (kg)	
NPS	DN	L	K	D	H1	H2	N-d	N-M	ISO5211	SXS	h	WF	LUG
2	50	44	125	99	125	66	4-18	4-M16	F05	11X11	16	5	6
2.5	65	46	145	118	138	78	8-18	8-M16	F05	11X11	16	6	7
3	80	48	160	132	156	100	8-18	8-M16	F07	14X14	18	7	9
4	100	54	190	156	168	115	8-22	8-M20	F07	14X14	22	8	10
5	125	56	220	184	188	135	8-26	8-M24	F10	17X17	22	11	14
6	150	57	250	211	205	150	8-26	8-M24	F10	17X17	22	15	18
8	200	64	310	274	240	182	12-26	12-M24	F12	22X22	27	22	28
10	250	71	370	330	280	216	12-30	12-M27	F12	22X22	27	34	40
12	300	81	430	389	322	256	16-30	16-M27	F14	27X27	32	53	68
14	350	92	490	448	375	285	16-33	16-M30	F14	27X27	32	60	85
16	400	102	550	503	400	325	16-36	16-M33	F14	36X36	42	82	95
18	450	114	600	548	480	350	20-36	20-M33	F16	36X36	42	130	156
20	500	127	660	609	512	402	20-36	20-M33	F16	46X46	54	170	210
24	600	154	770	720	570	455	20-39	20-M36	F16	46X46	54	265	320

PN40												重量 (KG)	
NPS	DN	L	K	D	H1	H2	N-d	N-M	ISO5211	SXS	h	WF	LUG
2	50	44	125	99	125	66	4-18	4-M16	F05	11X11	16	5	6
2.5	65	46	145	118	138	78	8-18	8-M16	F05	11X11	16	6	7
3	80	48	160	132	156	100	8-18	8-M16	F07	14X14	18	7	9
4	100	54	190	156	168	115	8-22	8-M20	F07	14X14	22	8	10
5	125	56	220	184	188	135	8-26	8-M24	F10	17X17	22	11	14
6	150	59	250	211	215	155	8-26	8-M24	F12	22X22	22	17	20
8	200	73	320	284	255	195	12-30	12-M27	F12	22X22	27	26	36
10	250	83	385	345	298	232	12-33	12-M30	F14	27X27	27	42	54
12	300	92	450	409	342	278	16-33	16-M30	F14	27X27	32	58	82
14	350	117	510	465	398	305	16-36	16-M33	F16	36X36	32	95	132
16	400	133	585	535	430	355	16-39	16-M36	F16	36X36	42	124	175

高性能蝶阀

High performance butterfly valve

高性能蝶阀

High performance butterfly valve

HD800系列蝶阀工程数据 Hd800 series butterfly valves engineering data

蝶板开启角度Opening angle of butterfly plate
流量系数表Flow coefficient table

CLASS 150LB/PN16,25

口径DN in mm	10°	20°	30°	40°	50°	60°	70°	80°	90°
2 50	6	10	19	34	51	78	105	134	163
2.5 65	6	10	19	34	53	80	111	148	175
3 80	8	12	24	43	67	100	139	186	220
4 100	16	13	44	80	130	194	269	360	425
5 125	30	44	83	149	242	366	504	673	795
6 150	50	70	130	230	370	550	760	1010	1175
8 200	83	117	251	437	695	1052	1496	2001	2420
10 250	144	202	454	754	1185	1821	2611	3541	4520
12 300	208	304	678	1051	1625	2766	3838	5325	1905
14 350	257	360	747	1186	1909	3121	4416	6225	8280
16 400	308	432	803	1422	2289	3614	5251	7530	10020
18 450	373	548	1121	1869	2990	4735	6728	9845	12410
20 500	463	680	1390	2315	4010	6175	8995	12655	15210
24 600	650	991	2076	3803	6060	9091	13301	18466	21450

CLASS 300LB/PN40

口径DN in mm	10°	20°	30°	40°	50°	60°	70°	80°	90°
2 50	6	10	19	34	51	78	105	134	160
2.5 65	6	10	19	34	53	80	111	148	170
3 80	8	12	24	43	67	100	135	185	215
4 100	16	13	44	80	130	194	269	360	413
5 125	30	44	83	149	242	366	504	663	785
6 150	50	70	130	230	370	550	760	1010	1140
8 200	83	117	251	437	695	1052	1495	2001	2300
10 250	144	202	454	754	1185	1821	2611	3541	4333
12 300	208	304	677	1051	1625	2766	3834	5325	6600
14 350	257	360	747	1185	1909	3121	4416	6225	7880
16 400	308	432	803	1421	2289	3614	5241	7520	9530
18 450	373	548	1121	1868	2990	4735	6714	9815	11350
20 500	463	680	1390	2315	4010	6175	8988	12455	14250
24 600	650	990	2075	3802	6055	9085	13300	18266	20550

注释Notes:

- 定义Definition
CV:温度为15°C时水通过阀门且压降为1PSI时的流量 (加仑/分钟)
CV: flow rate (GPM) at 15 °C through valve and 1psi pressure drop
KV:温度为15°C时水柱通过阀门且压降为1vbar时的流量 (m³/小时)
KV: flow rate when the water column passes through the valve and the pressure drop is 1vbar at 15 °C (m³ / h)
- 流向为阀杆端向阀座方向
Flow direction is from stem end to valve seat
- Cv=1.15Kv

阀门开启和关闭力矩表 opening and closing torque table

下表中所列为PTFE和RPTFE的扭矩值, 额定扭矩值可通过力矩表对应压力查得, 对其他不同的阀座材料请咨询我公司销售工程师

The torque values of PTFE and rptfe are listed in the table below. The rated torque value can be obtained through the corresponding pressure of torque gauge. For other different valve seat materials, please consult our sales engineer

阀门口径 DN		0.6Mpa	1.0Mpa	1.6Mpa	2.0Mpa	2.5Mpa	4.0Mpa	5.0Mpa
in	mm	Nm	Nm	Nm	Nm	Nm	Nm	Nm
2	50	25	26	29	35	38	45	50
2.5	65	29	31	35	40	45	52	61
3	80	34	37	42	46	52	63	72
4	100	47	51	55	58	79	97	110
5	125	65	76	81	86	128	168	185
6	150	97	103	116	126	188	241	278
8	200	164	185	198	217	368	477	554
10	250	222	262	288	318	572	756	885
12	300	290	375	425	475	790	1035	1207
14	350	491	645	724	849	1372	1882	2239
16	400	628	826	925	1087	1643	2248	2671
18	450	816	1084	1274	1423	2118		
20	500	1098	1386	1656	1926	2842		
24	600	1673	2155	2494	2983	3840		

注意事项Matters needing attention

- 表中扭矩值为室温下的设计计算值。在选择执行机构时, 应考虑一定的安全系数。
1. Torque value in the table is the design calculation value at room temperature. When choosing the actuator, a certain safety factor should be considered. Generally,
液体介质x1.3
Liquid medium x1.3
油品油脂x1.0
Oil and grease x1.0
湿润空气x1.4
Moist air x1.4
干燥空气 x1.8
Dry air X1.8
含固体的浆料 x1.5
Slurry containing solids X1.5
- 当实际压力小于表中数值时, 按公称压力值选择。
2. When the actual pressure is less than the value in the table, it shall be selected according to the nominal pressure value.
- 此表仅供参考。选择执行机构时请与我公司确认。我们保留不通知客户修改数据权利。
3. This form is for reference only. Please confirm with our company when choosing the executing agency. We reserve the right not to inform customers to modify the data.

齿轮箱

Worm Gear

驱动方式

Driving Mode

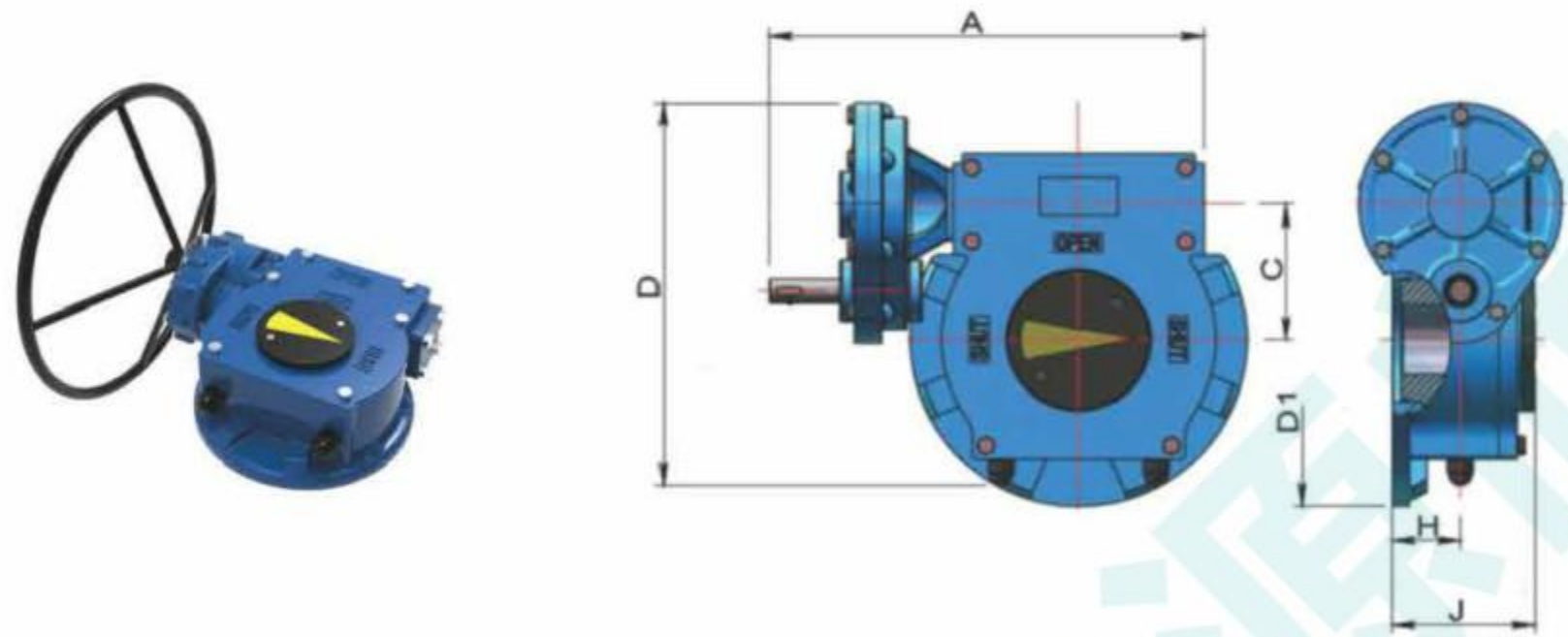

齿轮箱
Worm gear



双作用气动
pneumatic double-action



单作用气动
operating single-action

技术参数technical parameter						外形尺寸Overall dimension							
型号 Type	速比 Rratio	阀杆直径 Stem (Max)	输出	输入	放大系数 enlarge coefficient ± 15%	连接 法兰 ISO5211	D1	A	H	J	C	D	手轮 handwheel
			扭矩torqueNm										
SWV20	37:1	28	330	30	11	F07	90	185	29	64	52	140	200
SWV21	38:1	36	850	75	11	F10	125	200	36	74	62	162	300
SWVS30	40:1	45	1350	113	12	F12	175	219	46	93	79	202	350
SWV55	47:1	55	2000	142	14	F14	175	241	50	99	89	223	400
SWV88	61:1	65	3000	164	18	F16	210	290	55	115	112	267	500
SWV88-2.5	130:1	65	4000	121	33	F16	210	367	55	115	112	276	500
SWV195-2.5	130:1	80	5000	151	33	F16	210	391	62	125	129	307	600
SWV195-3.2	167:1	80	6500	153	43	F16	210		600				
SWV300-5	290:1	95	9500	128	74	F25	300	473	70	153	157	412	600
SWV300-6	348:1	95	11000	146	75	F25	300	500	70	153	157	385	600
SWV680-6	372:1	110	13500	167	81	F30	350	563	71	156	182	424	600
SWV680-8	519:1	110	16000	142	112	F30	350		600				
SWV780-11	627:1	130	24000	175	126	F35	415	600	96	193	200	465	600
SWV980-19	702:1	140	30000	190	70	F35	415	695	95	190	220	555	700
SWV1080-21	1110:1	145	40000	175	222	F40	475	690	152	223	230	570	700
SWV1180-29	1658:1	180	60000	170	331	F40	475	690	139	221	275	631	700



智能电装
Smart electric



精小型电装
Fine small electric



气液动
pneumatic-hydrodynamic



电液动
electric-hydraulic



液动
hydraulic

高性能蝶阀

High performance butterfly valve

高性能蝶阀

High performance butterfly valve

选型说明Model Selector:

SD	G	F	B	04	C	N	01	05	N
A	B	C	D	E	F	G	H	I	J

示例example:

SD G F B 04 C N 01 05 N

金属硬密封蝶阀、齿轮传动、RF法兰式、300LB 4"、密封圈SS316+石墨,阀座F51,阀体WCB,蝶板CF8M,阀杆17-4PH
SD-Metal hard seal butterfly valve, worm gear box operation, RF flange connection, CLASS300, Size 4", Sealing ring Ss316+Graphite, seat F51, Body WCB,Disc CF8M, Stem 17-4PH

(a) 阀门类型 valve Type
SD-多层次硬密封蝶阀 Multi-level Hard Seal Butterfly
MD-全金属硬密封蝶阀 Full Metal Hard Seal Butterfly
HD-高性能蝶阀 High Performance Butterfly Valve

(f) 密封圈 sealing Ring
A-431+石墨 Graphite B-2205+石墨 Graphite
C-316+石墨 Graphite D-Monel+石墨 Graphite
H-13Cr P-SS304 R-SS316 F-2205 M-Monel S-Stellite

(b) 操作方式 operational Mode
O-裸轴 Bare axis G-齿轮箱 Worm gear box E-电动执行器 Electric actuator
P-气动执行器 Pneumatic actuator H-液动 Hydraulic operation

(g) 阀座 seat
H-13Cr P-SS304 R-SS316 N-F51 M-Monel
S-Stellite T-WC-Co F-PTFE B-RPTFE K-UHMWPE C-FKM
X-NBR E=EPDM

(c) 连接方式 connection
W-对夹式 Wafer L-支耳式 LUG F-凸面法兰 RF Flange
M-凹面法兰 FM Flange R-环连接法兰 RTJ Flange B-对焊 Butt welding

(h) 阀体 body
01-WCB 02-A105 03-LCB 04-CF8
05-CF8M 06-4A/6A 07-Ductile iron
08-Copper alloy 09-Other

(d) 压力等级 pressure
A-150LB B-300LB C-600LB D-900LB E-1500LB
F-PN6 G-PN10 H-PN16 I-PN25 J-PN40
K-PN63 L-PN100 M-PN160 N-PN250

(i) 蝶板 disc
01-WCB 02-A105 03-LCB 04-CF8
05-CF8M 06-4A/6A 07-Ductile iron
08-Copper alloy 09-Other

(e) 阀门尺寸 size
03-3"(80) 14-14"(350) 30-30"(750)
04-4"(100) 16-16"(400) 32-32"(800)
05-5"(125) 18-18"(450) 34-34"(850)
06-6"(150) 20-20"(500) 36-20"(900)
08-8"(200) 24-24"(600) 40-24"(1000)
10-10"(250) 26-26"(650) 44-44"(1100)
12-12"(300) 28-28"(700) 48-48"(1200)

(j) 阀杆 stem
C-420 (2Cr12) P-431(1Cr17Ni2) N-630(17-4PH)
X-XM19 (Nitronic 50) U-2205/2507 K-Monel



标准规范 Standard Specification:

设计标准 Design standard:
API609, MSS SP-68, ASME B16.34, AWWAC504, BS EN593, GB/T8527, GB/T12224

结构长度 Face to face dimension standard:
API609, AWWAC504, BS EN558, GB/T12221

连接尺寸 Flange connection dimension:
ASME B16.5 (NPS≤24), ASME B16.47, ISO7005, BS EN1092, GB/T9113

对焊连接 Weld ends dimension standard:
ASME B16.25, GB/T12224

温度压力等级表 Temperature and pressure rating table:
ASME B16.34, GB/T12224

压力测试 Pressure test:
API598, ISO5208, BS EN12266, GB/T13927

防火试验 Fire safe standard:
API607, ISO10497

逸散性排放测试 Fugitive emission test:
ISO 15848, API622

执行机构安装 Actuator installation:
ISO5211

质量标准 Quality standard:
ISO9001, CE/PED

如果阀门按照其他标准制造或要求, 请联系我们
If the valve is to be made according to other standards or requirements, please contact us